

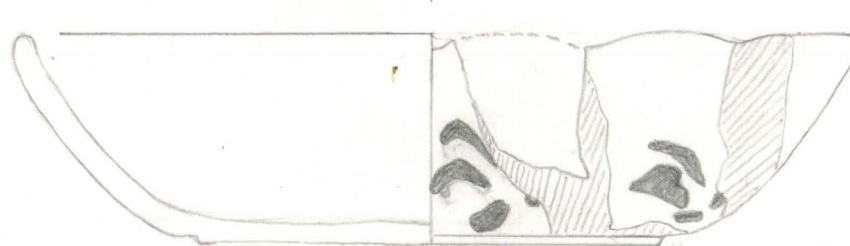

Alt. 34mm ϕ 76mm FF 12.97
Note-se a falta de simetria.
Note-se a tonalidade do azul.



FF 916  -s/vidrado ϕ 64mm Alt. 28mm

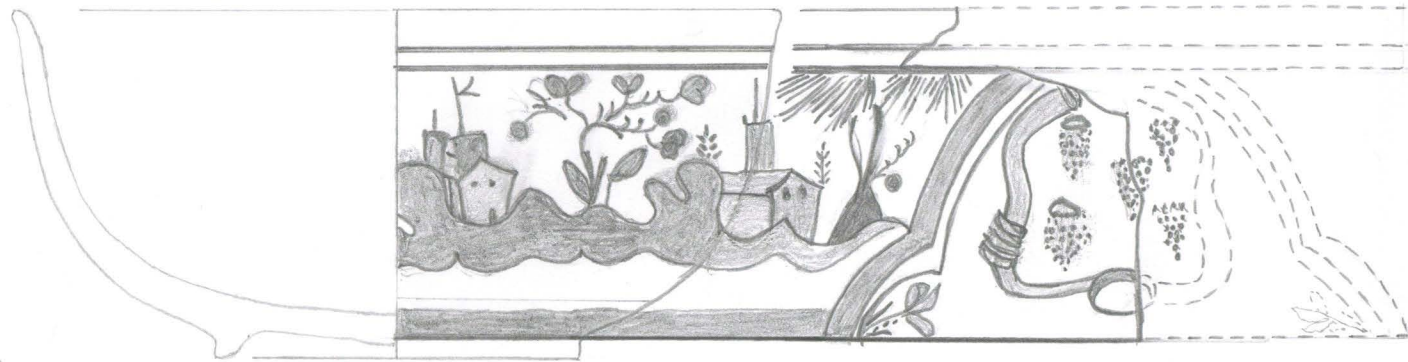
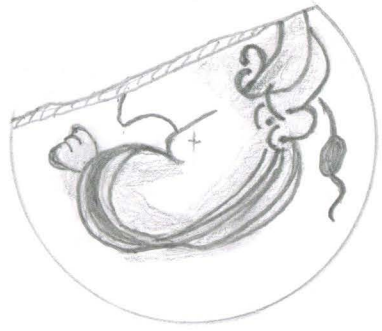

Alt. 46 mm
φ 100 mm

FF 420 N.º 420
Azuleirinho

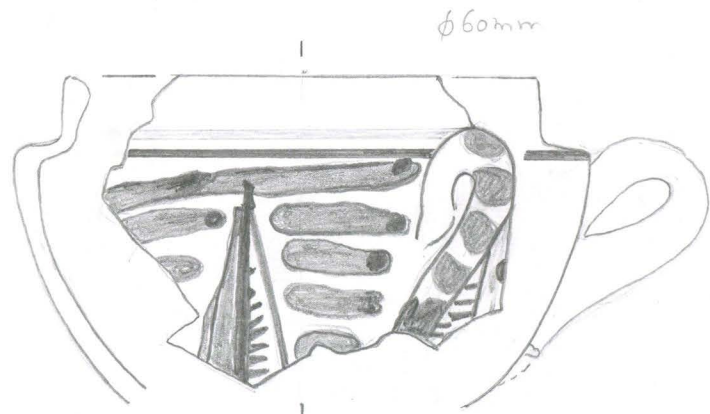

FF 1387



FF 408

φ74mm

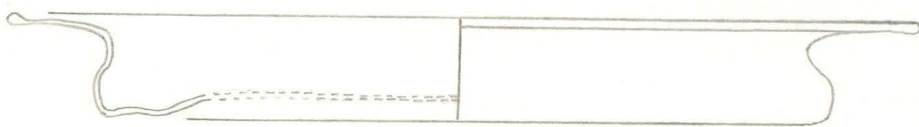

D'f R. II

2:3

SCV - Pizusa

Fai ANÇA

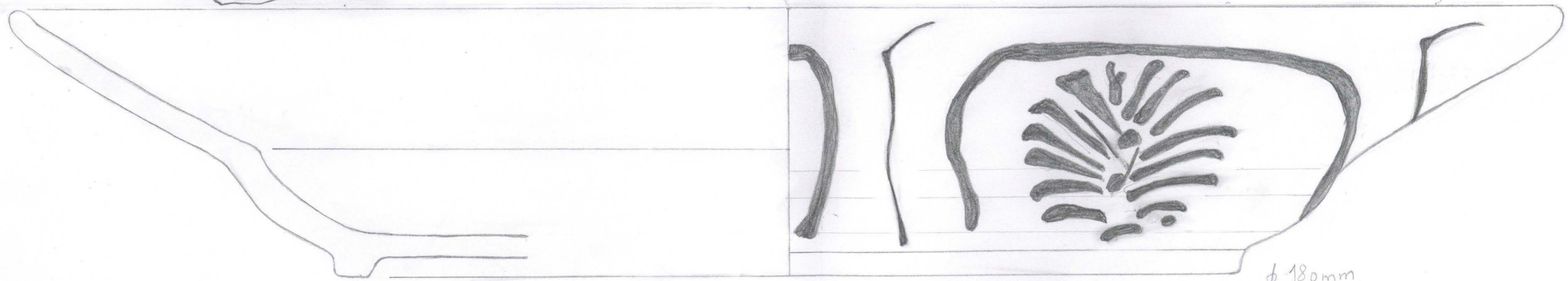

ϕ 327 mm

Alt. 55 mm

ϕ 180 mm

SCV - Faianga

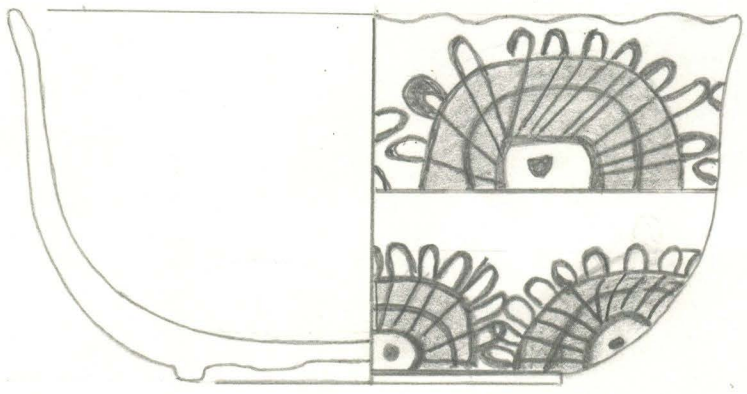

Alt. 49 mm
 ϕ 96 mm

ϕ 50 mm

FF 859

Faianga

φ 224 mm

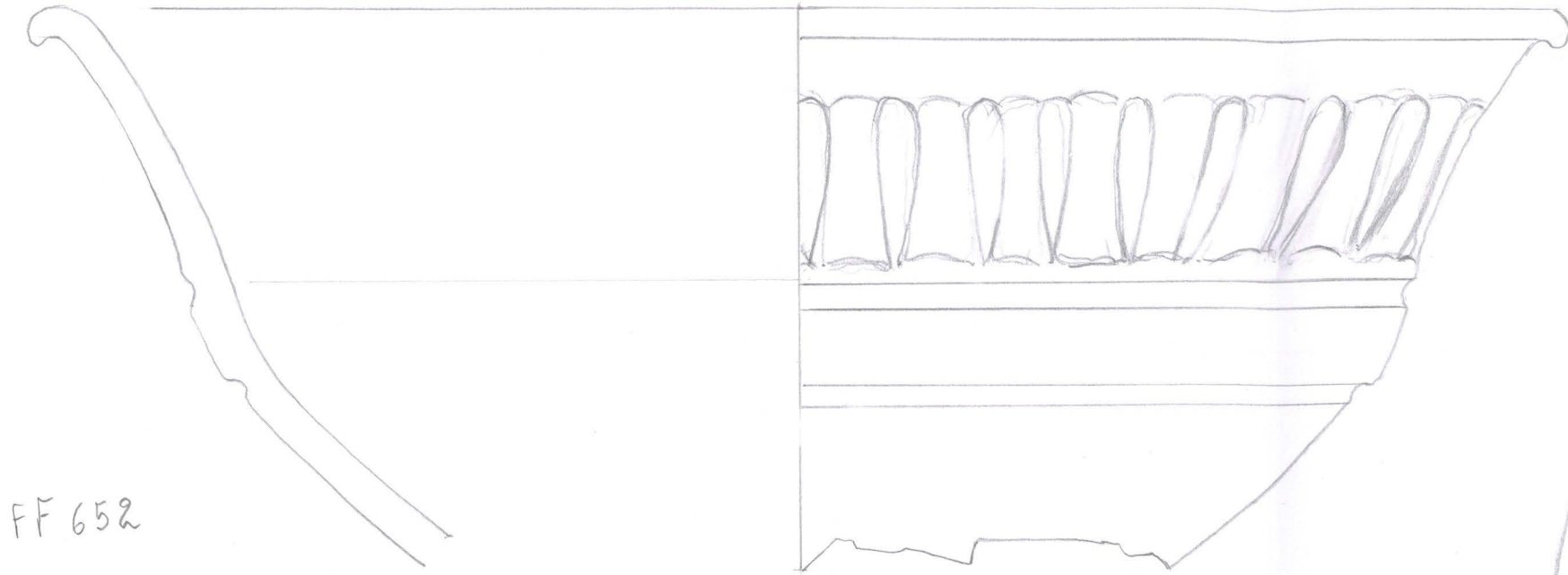

FF 652

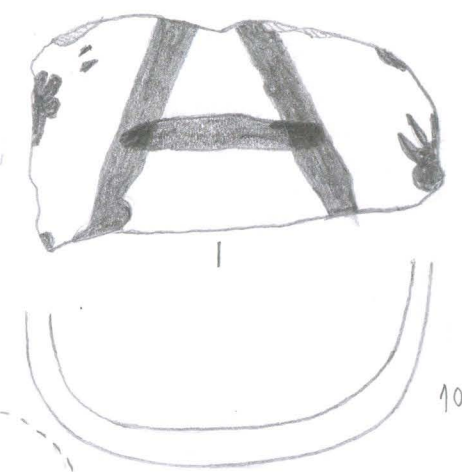

10.12.96 Sep. 41

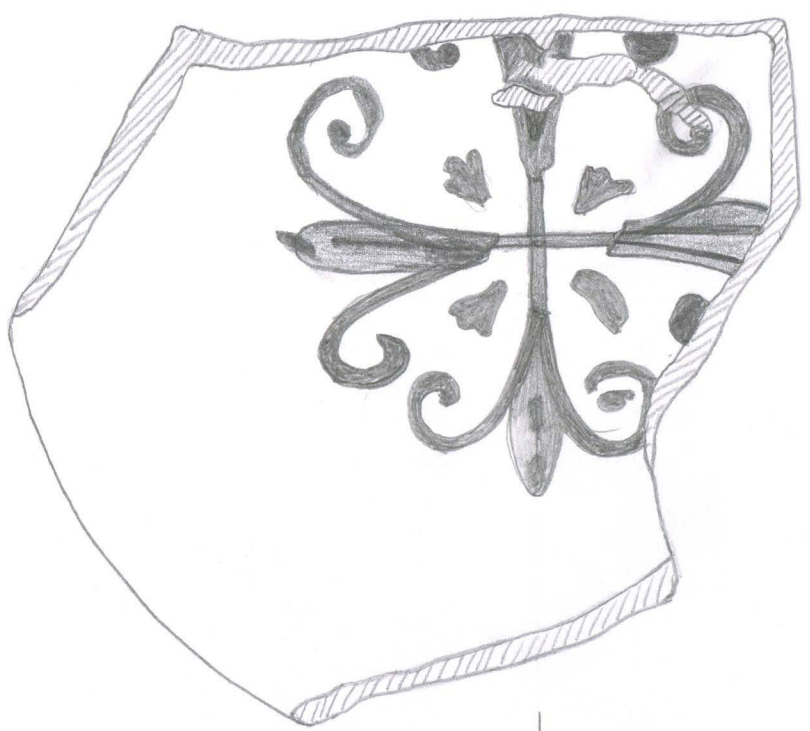
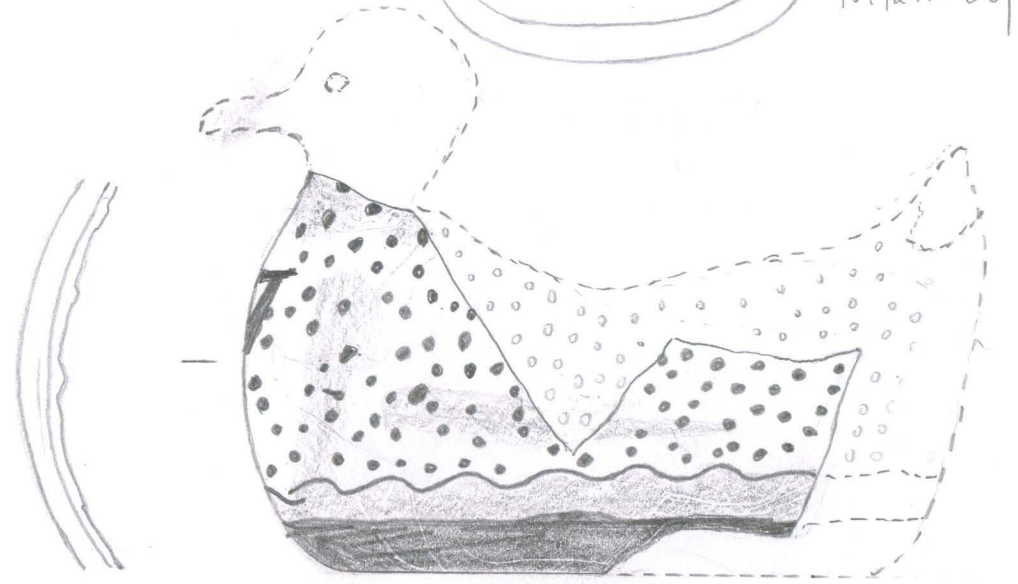

φ 142 mm

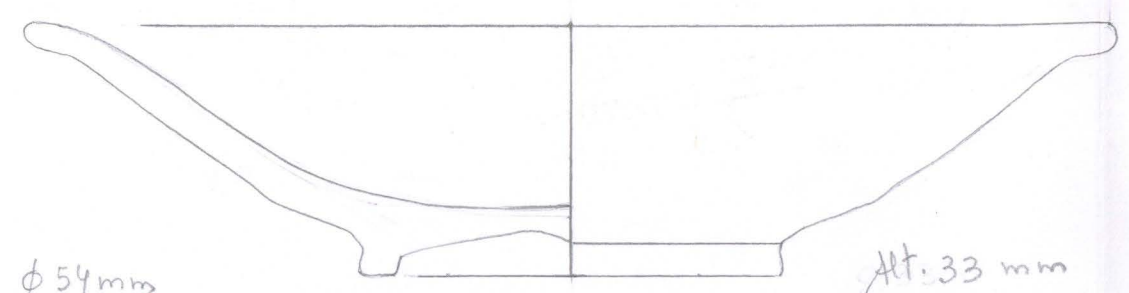

φ 54 mm

Alt. 33 mm



FF 1252

■ - azul escuro 5CV 96/5/21
 ■ - azul claro C'5 a II Tona negra

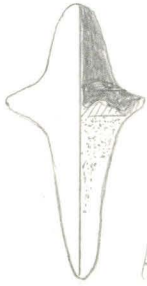
Inscricao no papo do pato: **V** 1:1



Alt. 36 mm

-  - azul
 -  - branco
 -  - fractura
- S/nº Inv:º

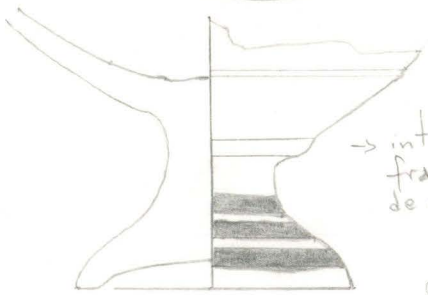
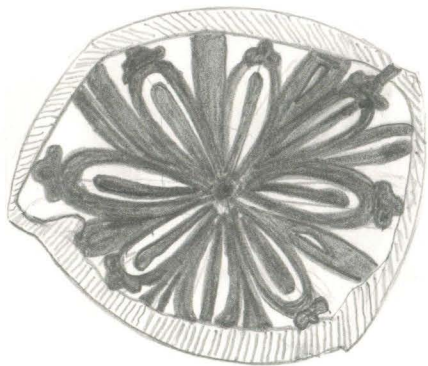



→ intenção frustrada de moldura

φ 38 mm

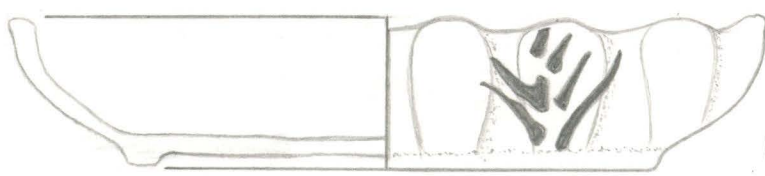
FF 701



φ 100 mm
Alt. 20 mm

-  - azul escuro
-  - azul claro
-  - amarelo

FF 1235

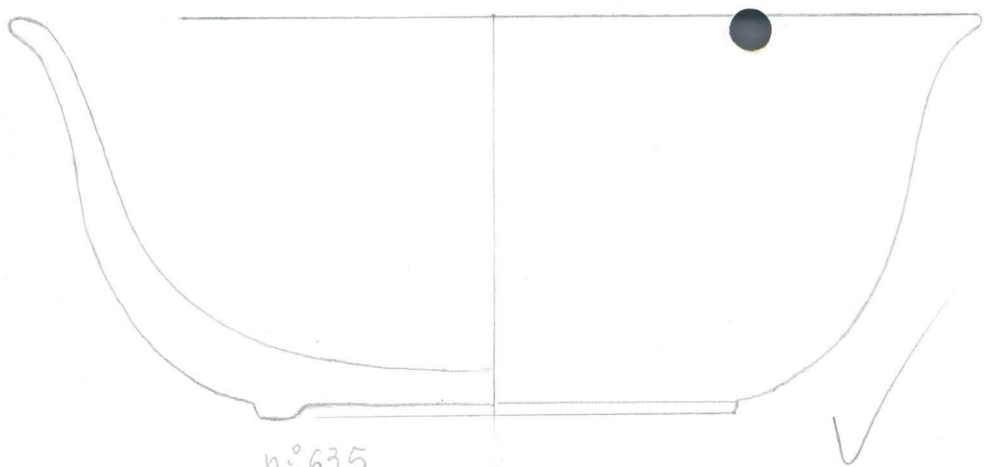

$\phi 127 \text{ mm}$
Alt. 52 mm

n.º 635

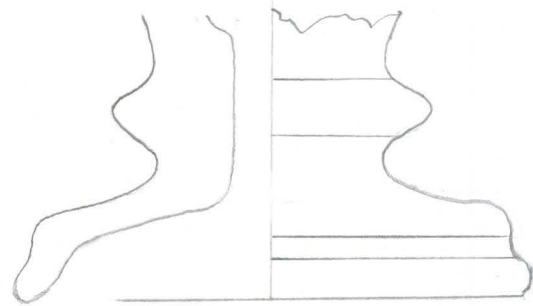

n.º 690 SCV 96

$\phi 67 \text{ mm}$

FAIANÇA
BRANCA
E
ZINZADA

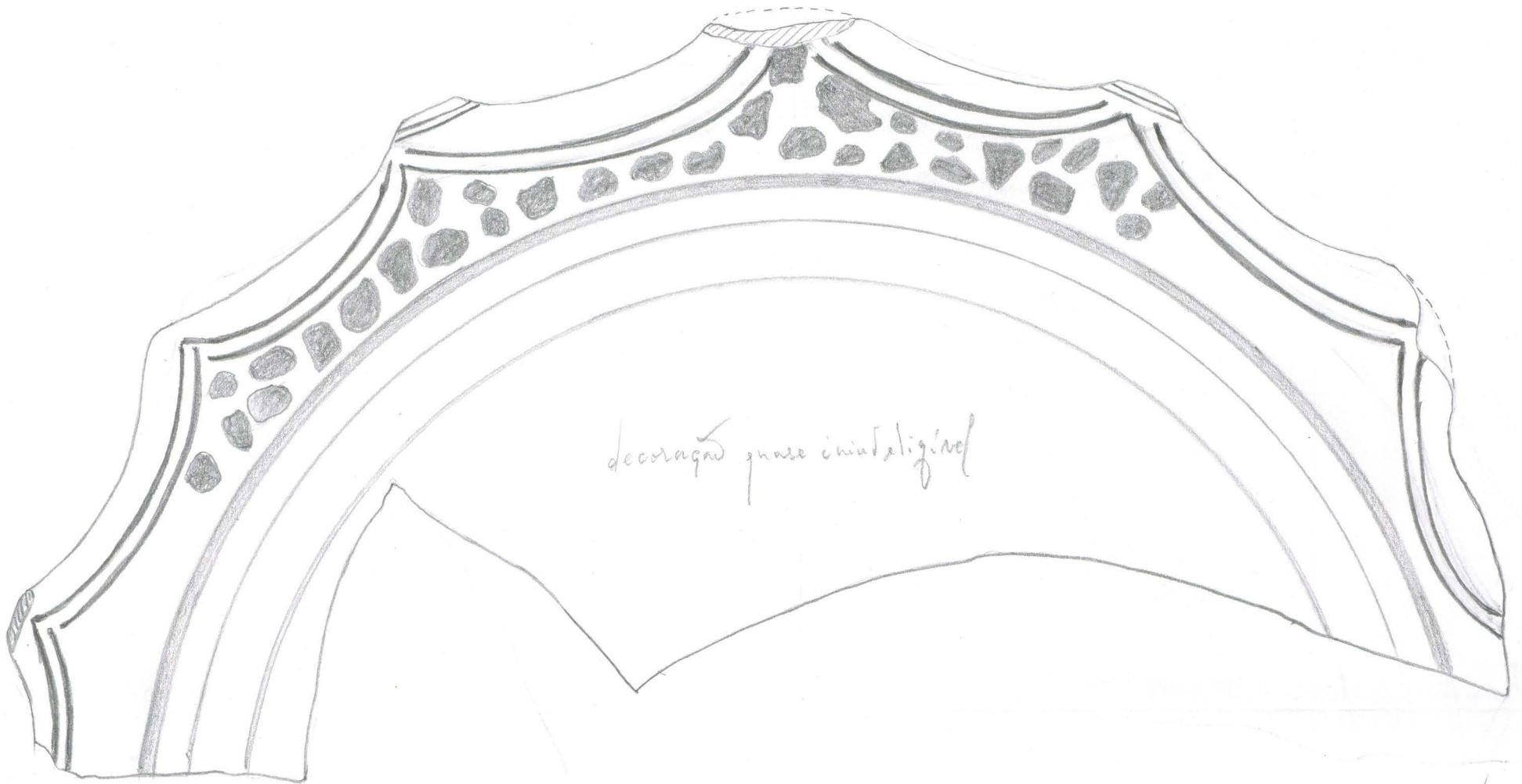

decoração quase ininteligível

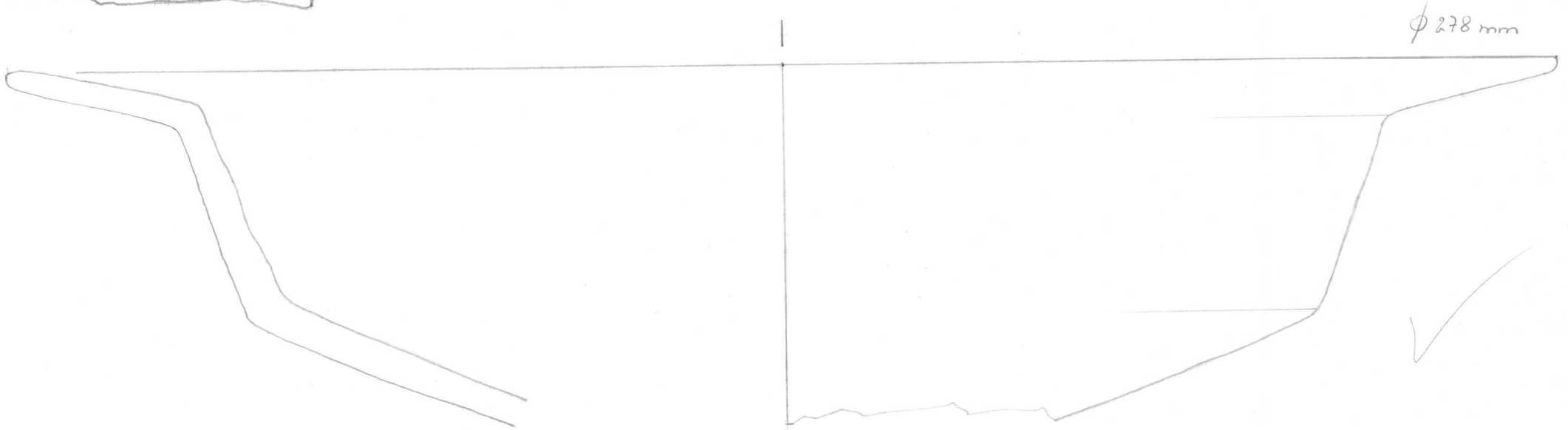

$\phi 278 \text{ mm}$

SCV 1996

N.º 628

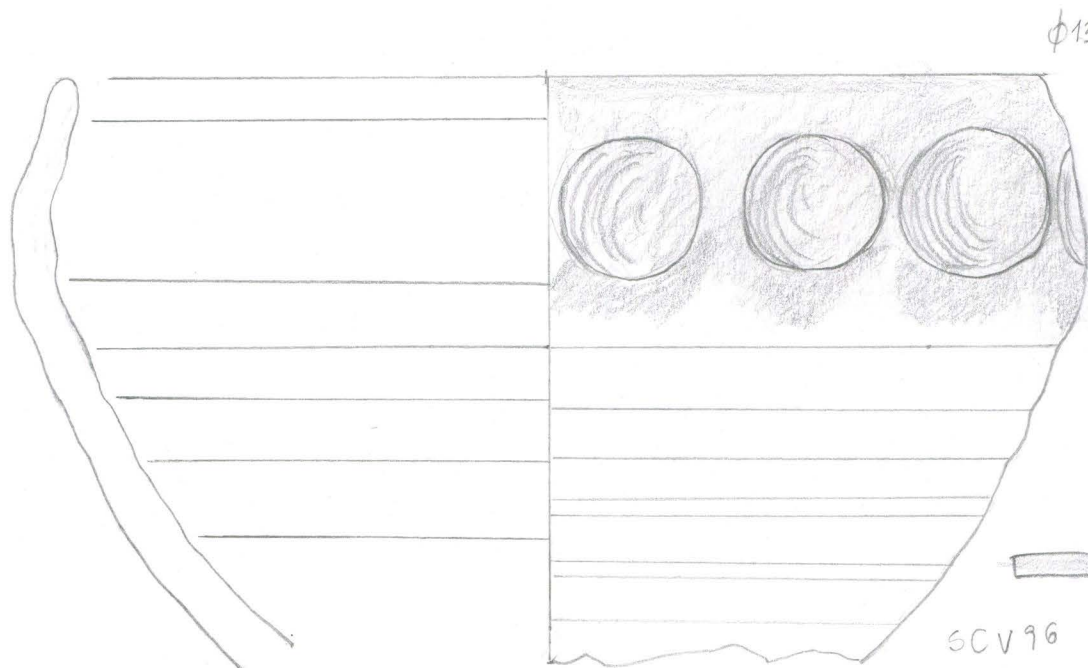

$\phi 132 \text{ mm}$

— vidro verde
SCV 96 A1 QI n.º 636

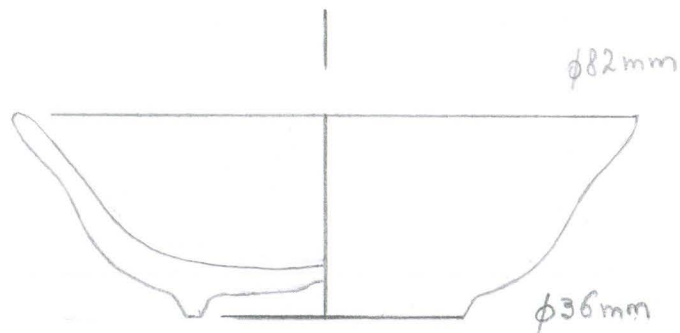

SCV 97/4/90 G'3 Q. III - IV FF 965

Localização P 2

Alt. 27mm

fai'arça

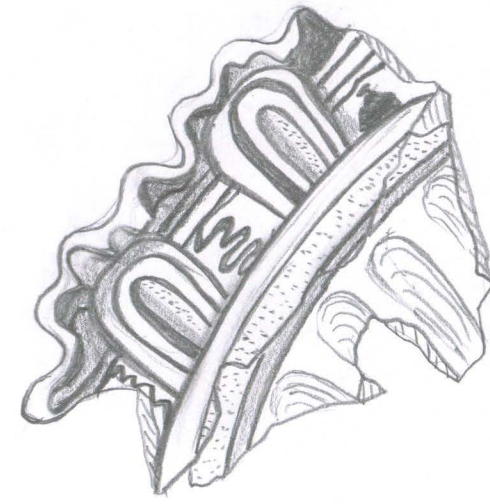

- azul escuro
- azul claro
- amarelo

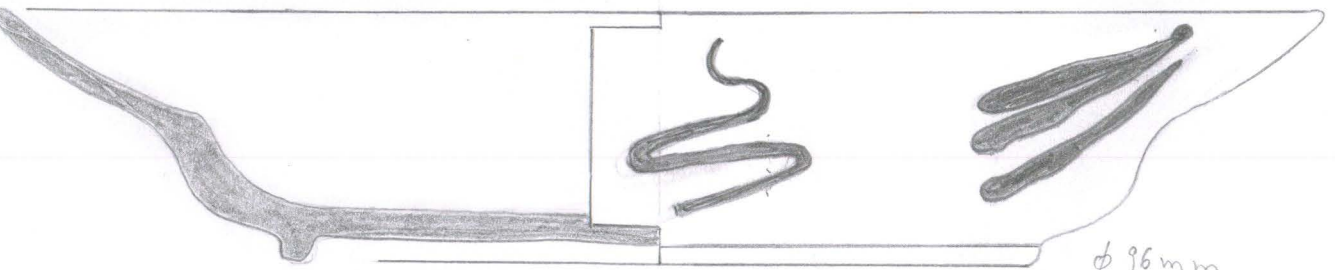
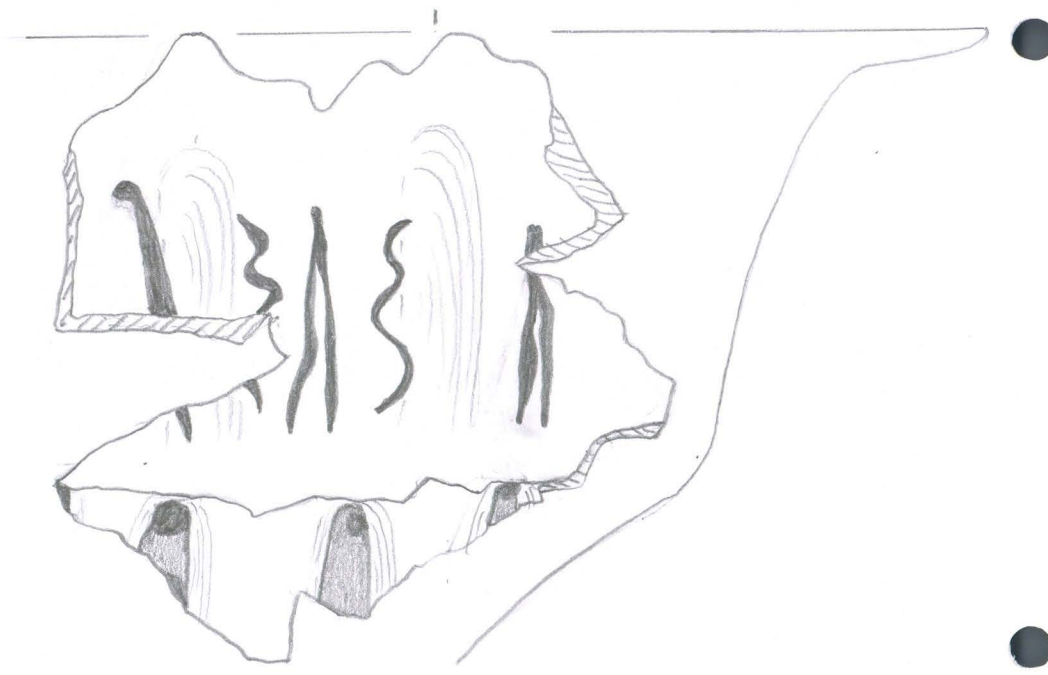

ff 1365

φ 96mm

Faiansa malagueira

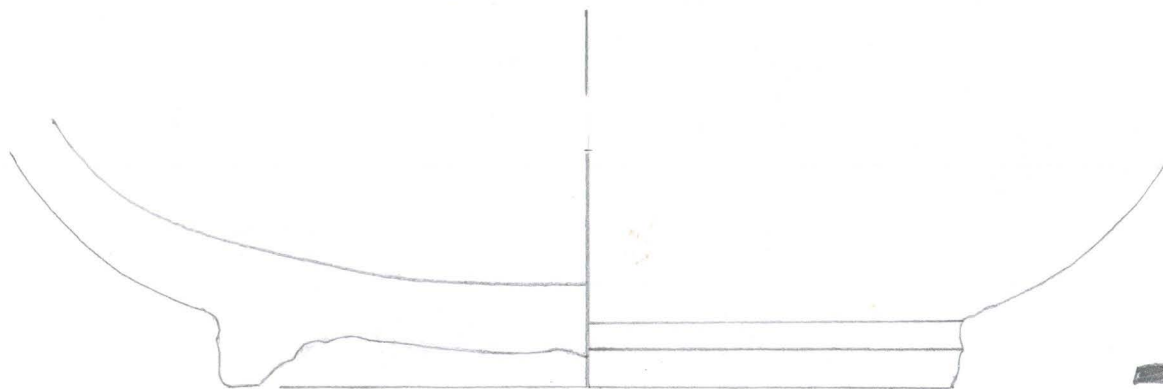

FF 1310 SCV05 B'1 Q. III Sond. D-46

■ - azul acinzentada
— Pasta vermelha pálida —

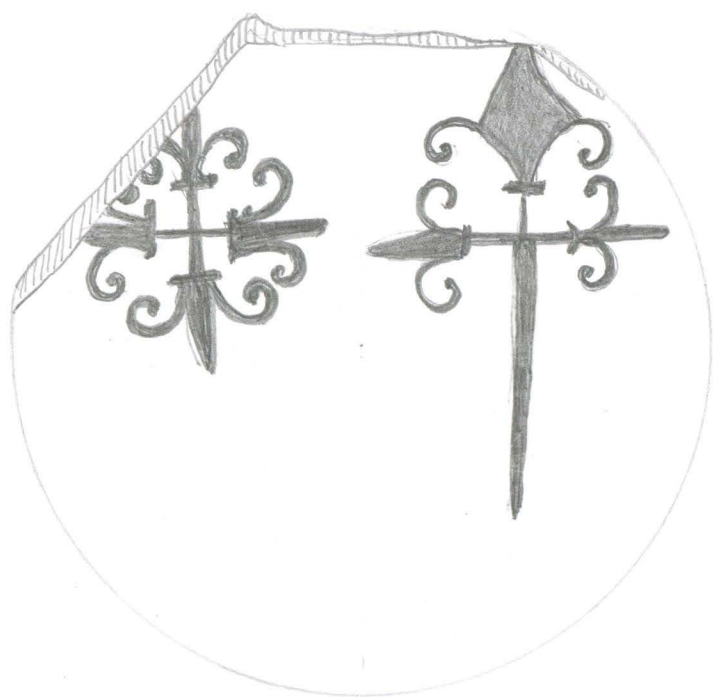

Alt. 34mm
φ 162

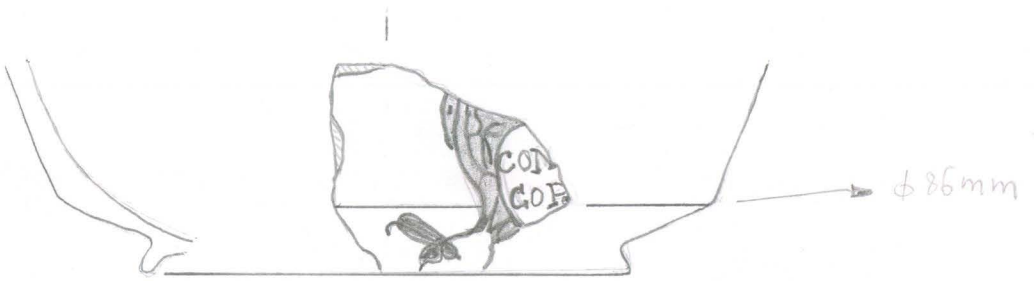
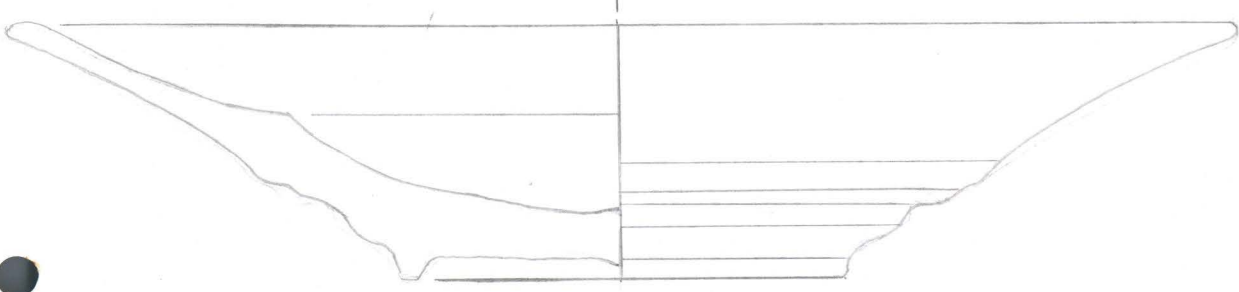

FF 26
— azul
— rinoso

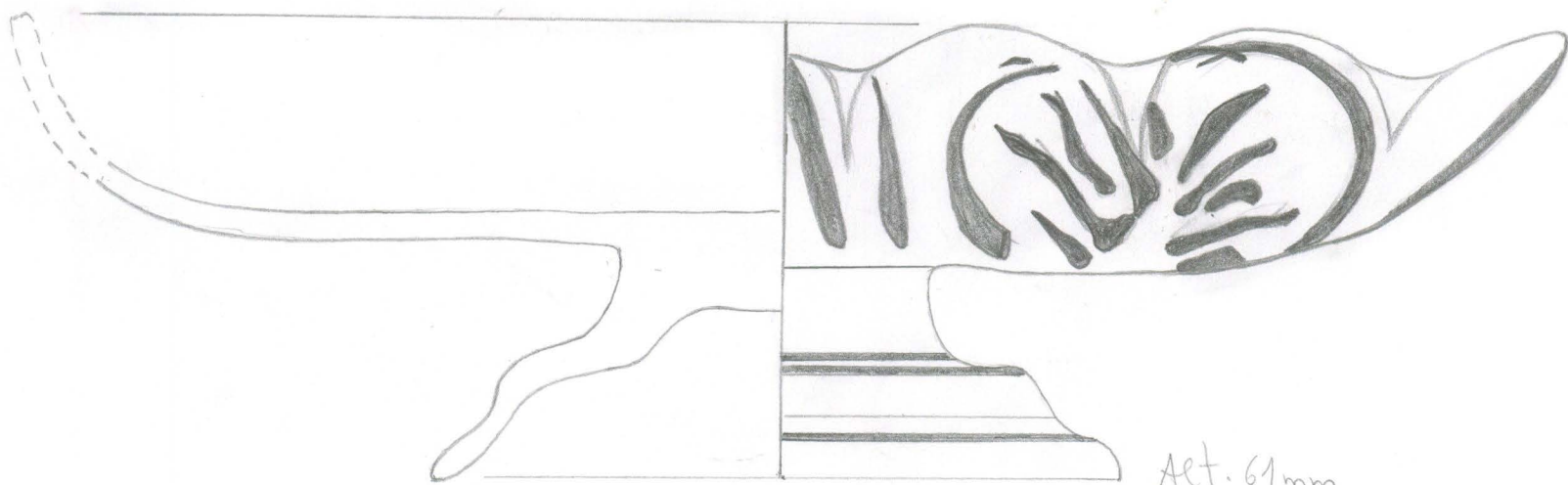
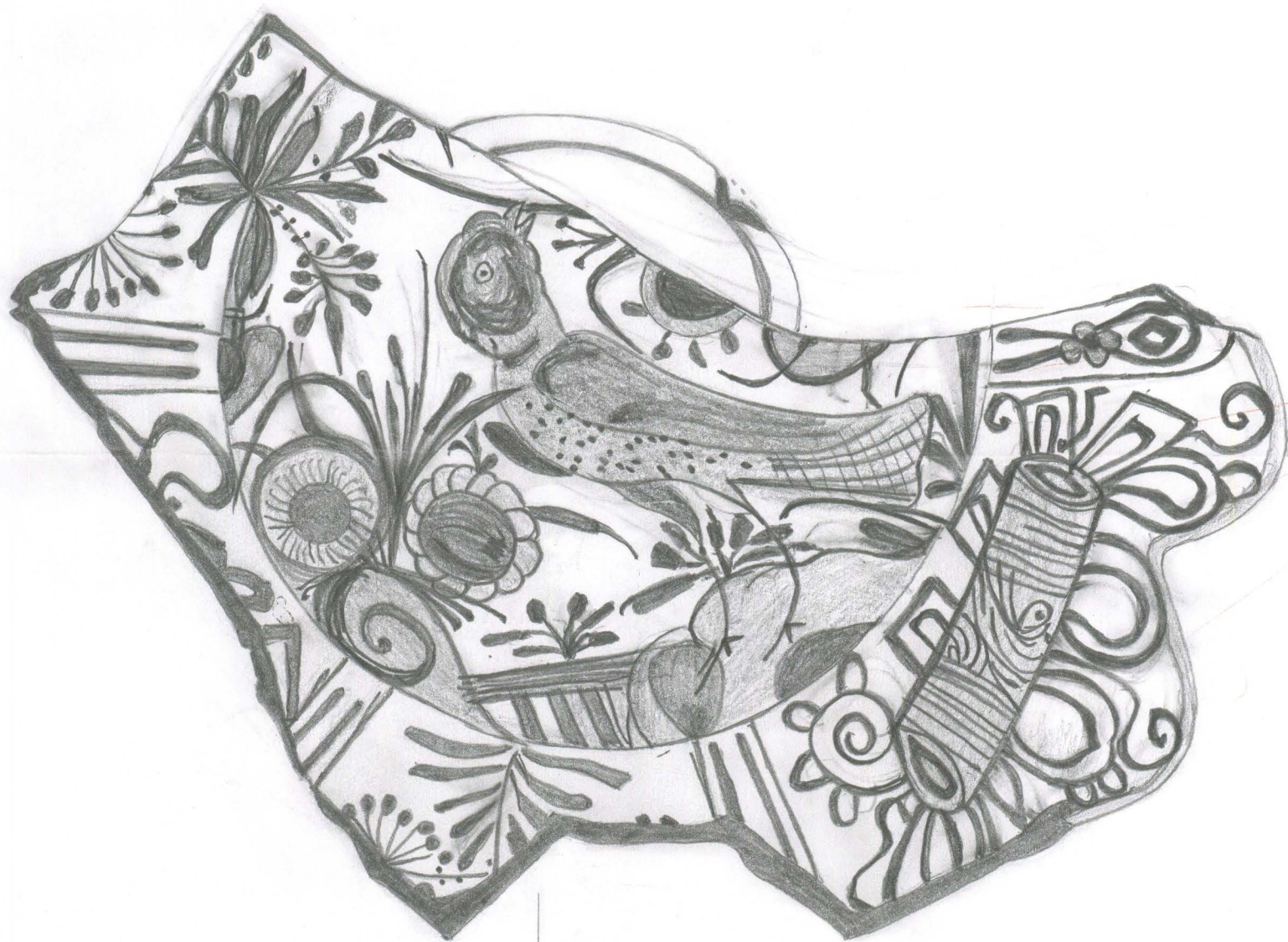

Alt. 61mm

FF608
Localizaãõ - J2
Tons de azul, unicamente



SCV I. 2420/2421/2675

Faiãnsa

$\phi 64\text{mm}$

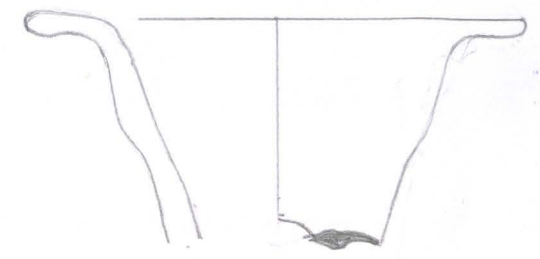

SCV 96 n: 636

■ azul
aba de contornos irregular

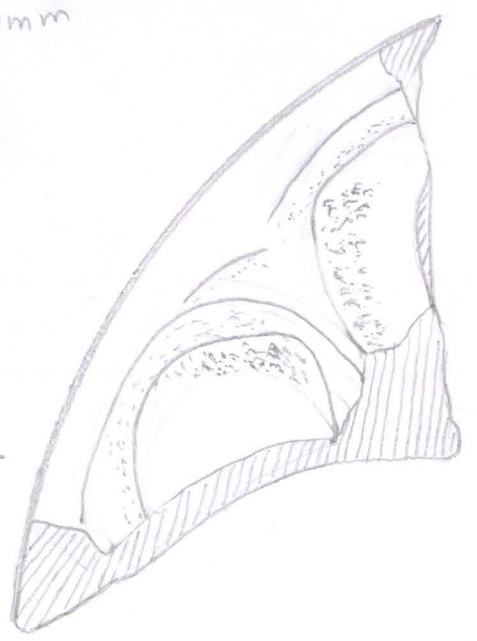

$\phi 200\text{mm}$

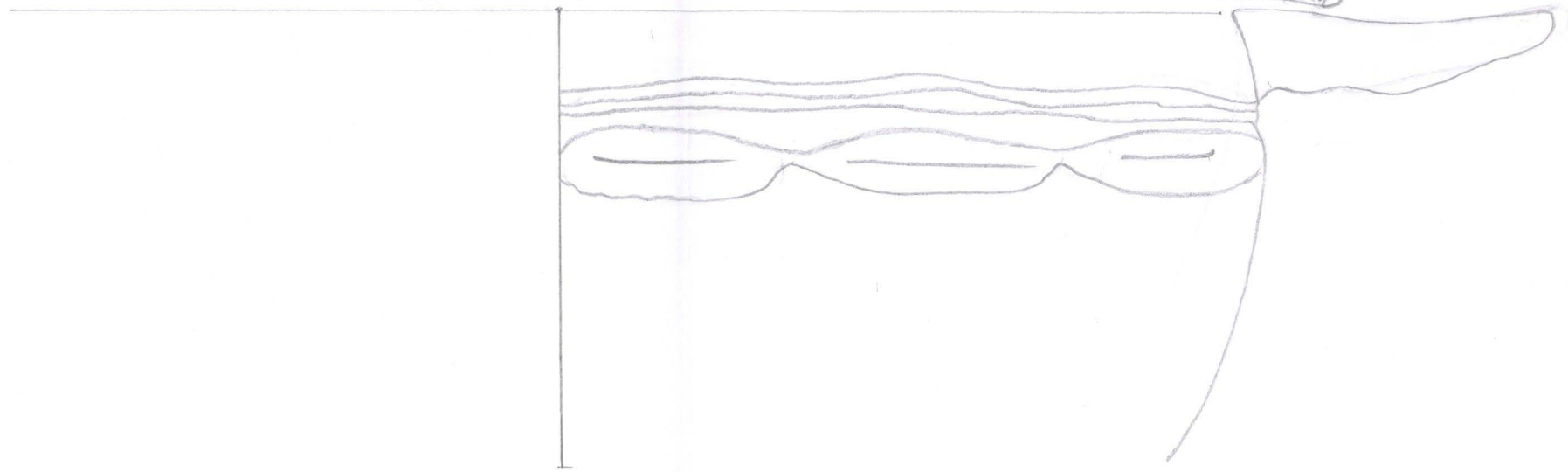
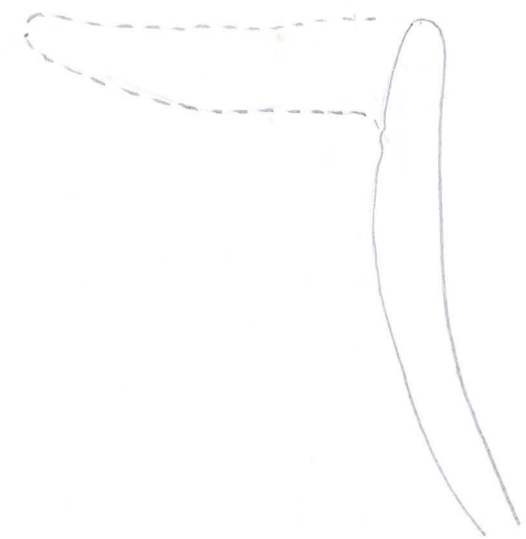
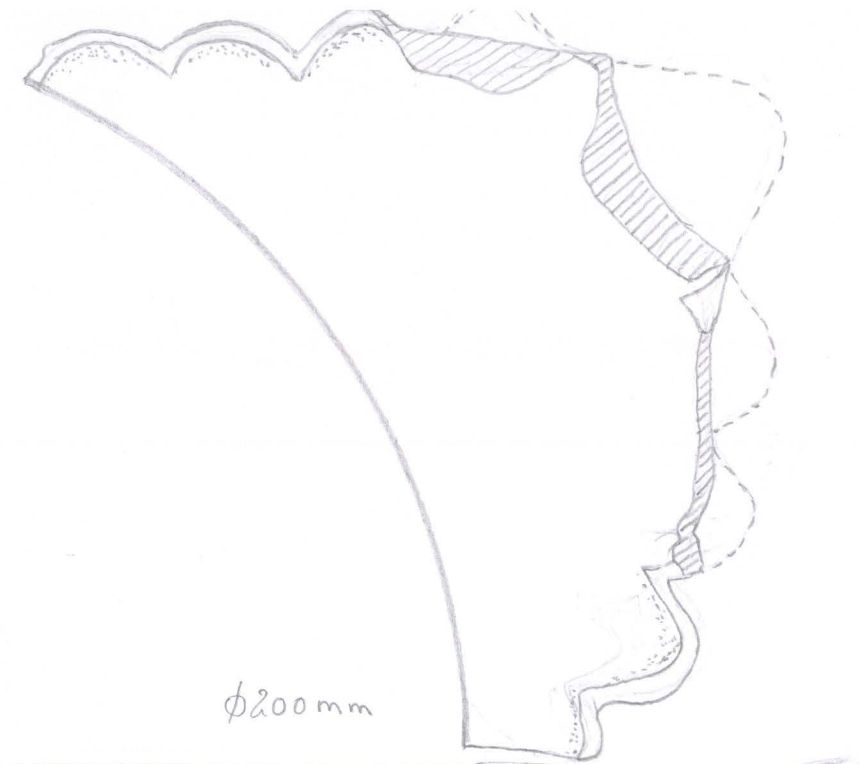

SCV 90 n: 635

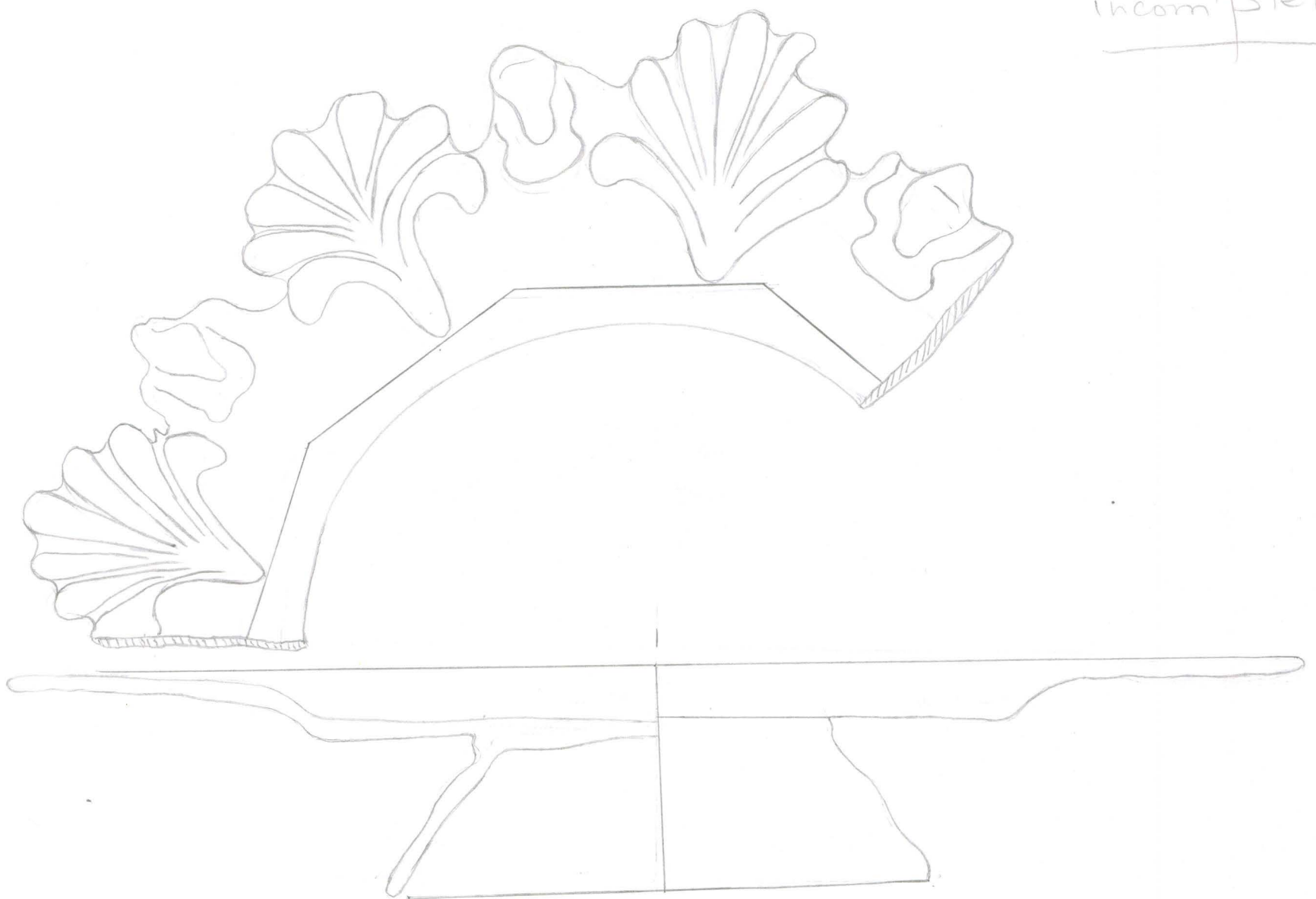

incompleta

scr c's a. III Lodo

muito irregular

FF 1158

Conjectural

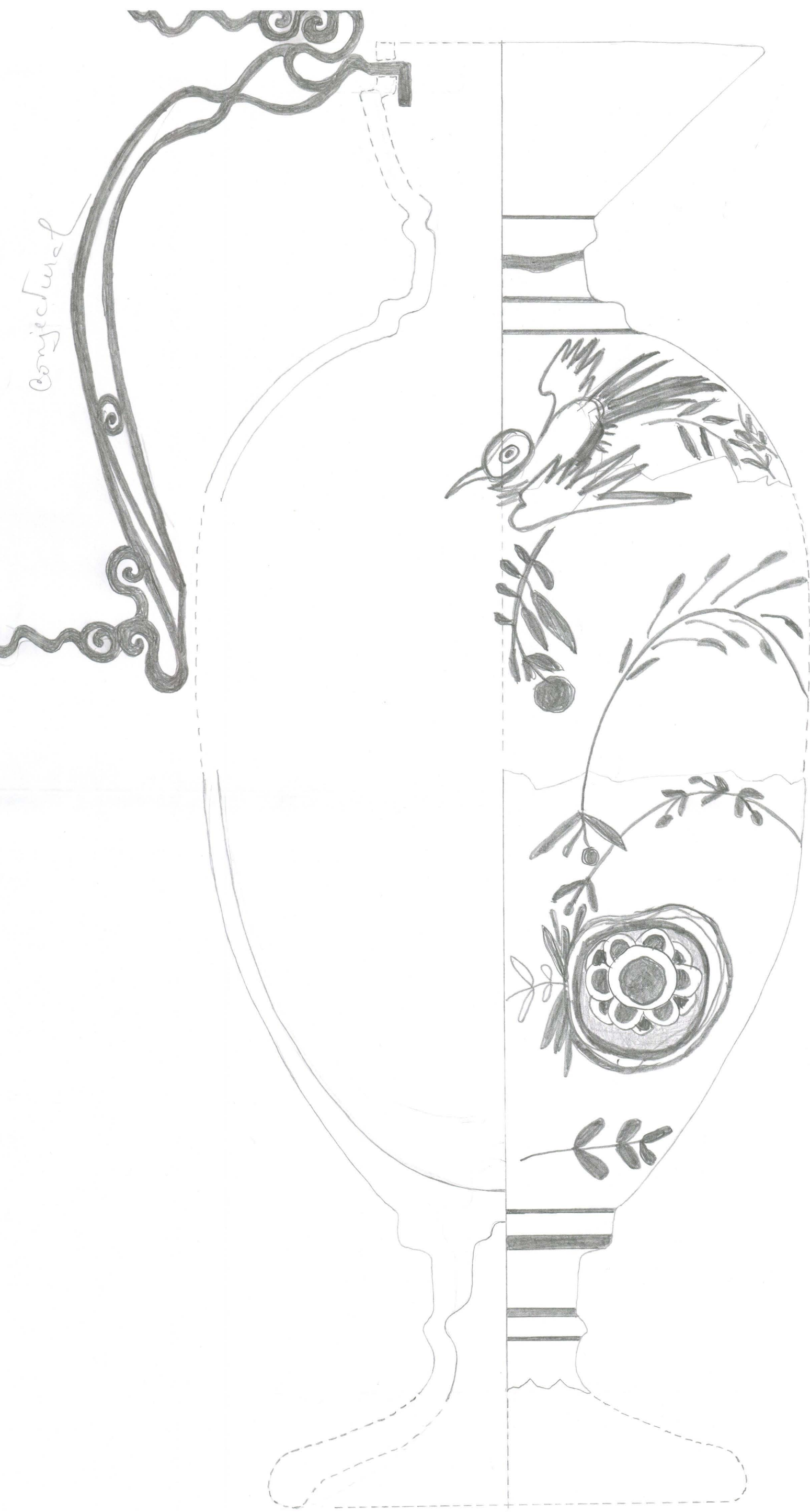

27.12.96 C'3 I - III

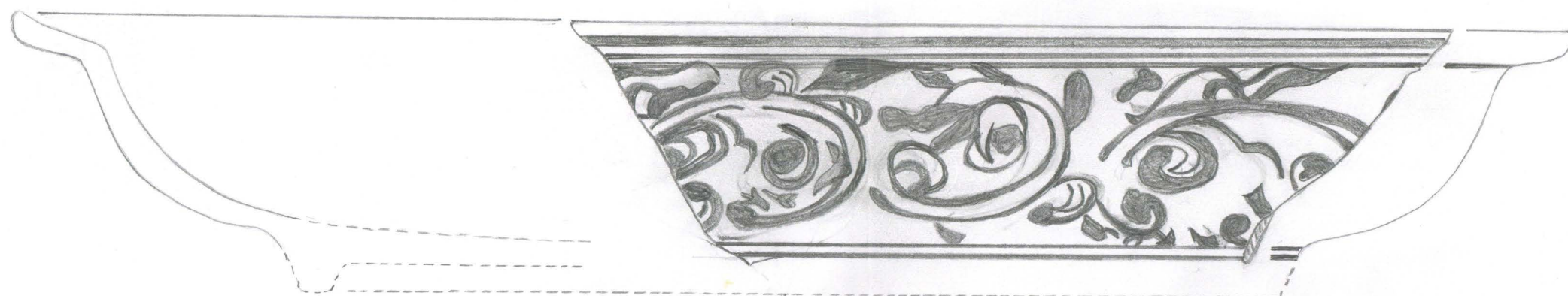

φ 272 mm

Cat. nº 10 SCV 97 P 2801 P 260

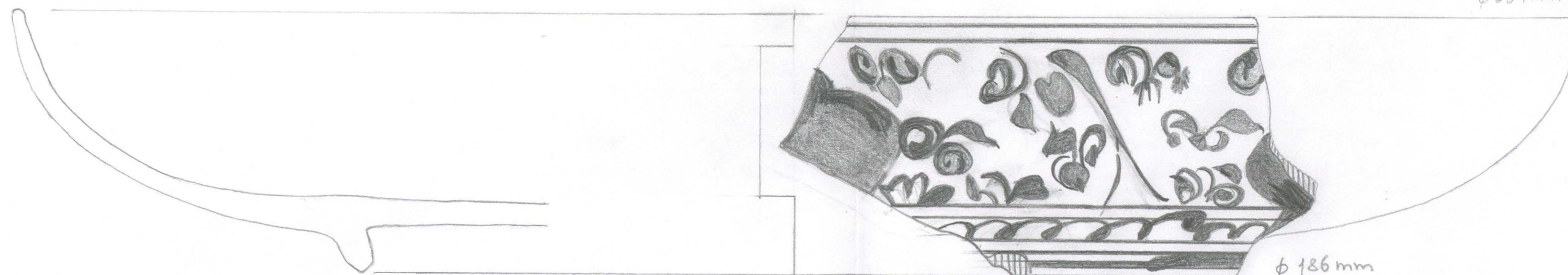

Alt. 56 mm

φ 334 mm

φ 186 mm

SCV P. 2420 (outro fragmento: SCV 96 SCV P. 2675)

lado interno: P. 2420 + 2421 + 2675 - folha anexa (montagem em A4)

φ106mm Faianga

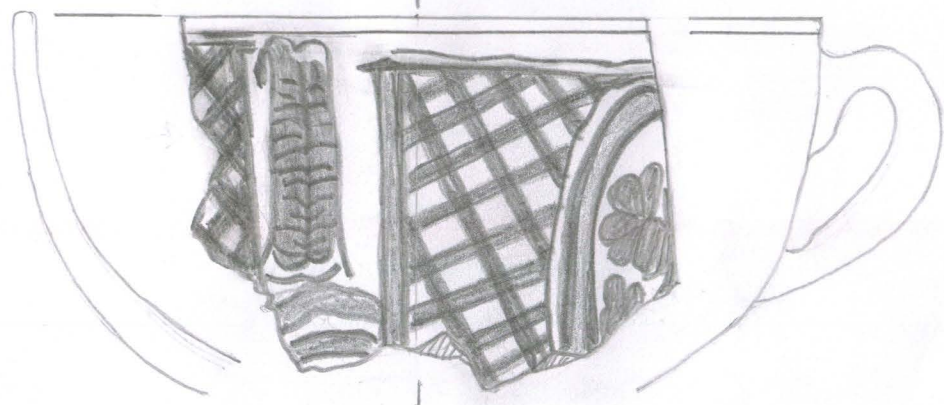

FF1404

— - azul escuro
— - azul claro

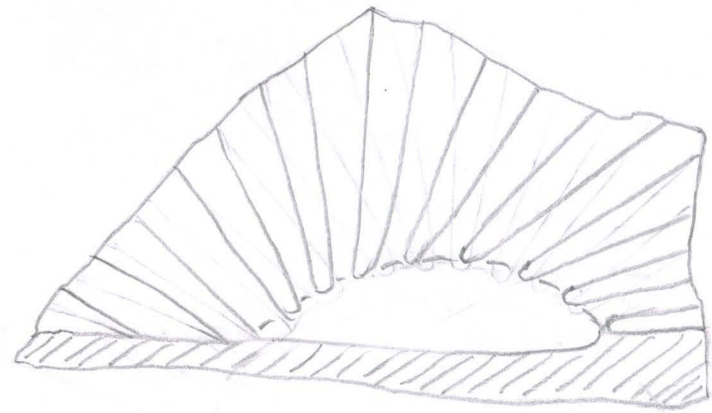

φ56mm

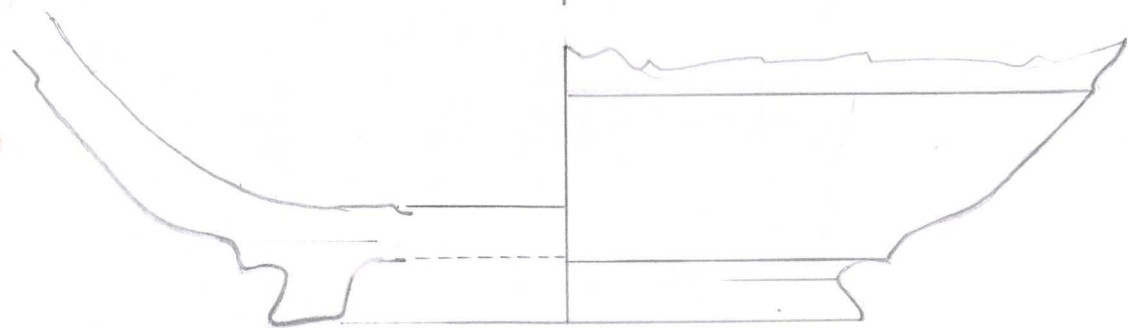

SCV 2006 N: 633

Vidrado - Verde — (meth. —)
Pasta — — — — (meth. —)

(Comem vidrada a verde. Receite? Vidrado a analisar em Ix, se a Augusta se interessar pelo caso.)

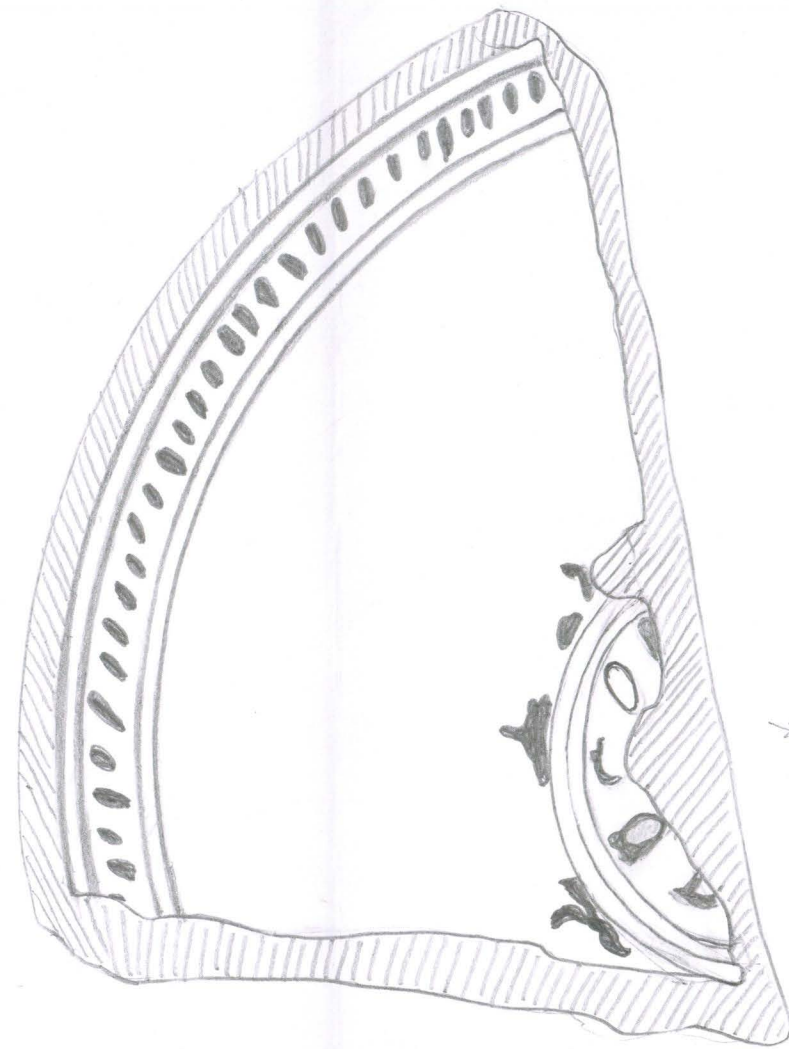

→ descentrado

φ214mm Faianga

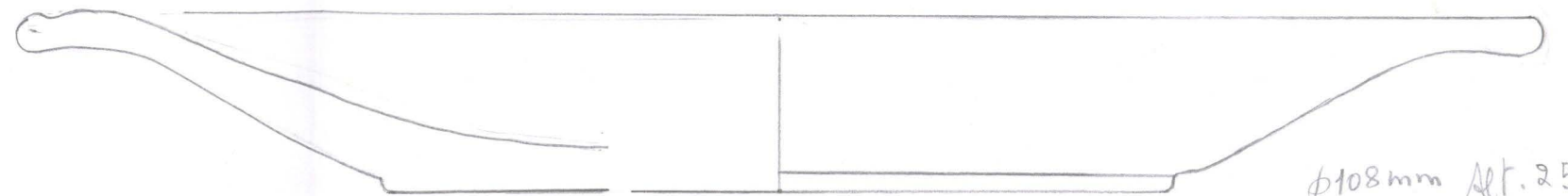

φ108mm Alt. 25mm

SCV 96 A1 Q.I n: 699

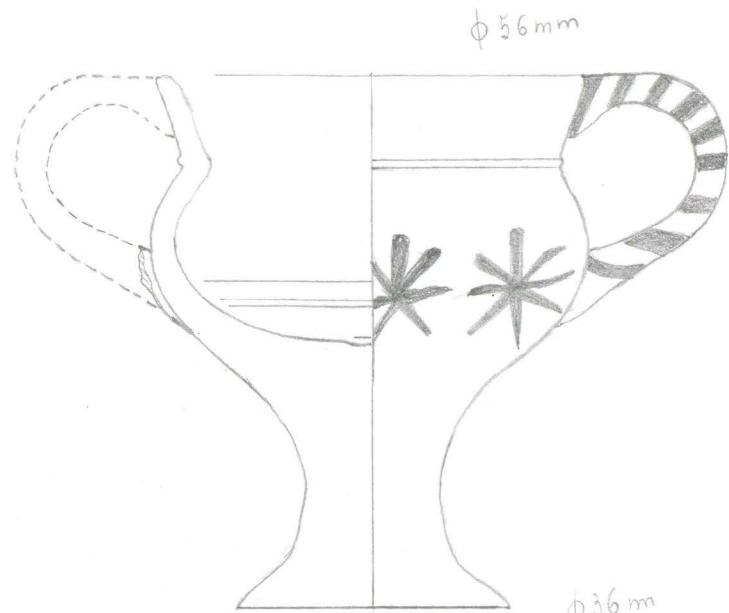

28.1.97 E'1 III Lodo [543]

— azul claro; pasta amarelada

BOTICA (Lembrar símbolo Farmácia)

φ 36mm
Alt. 70mm

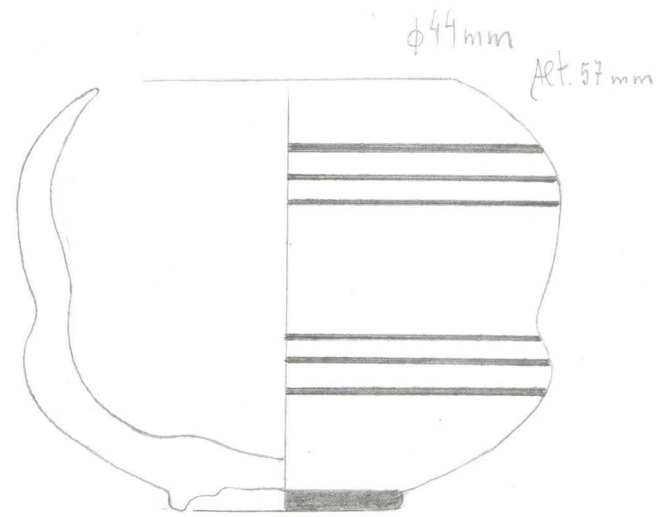

27.1.97 E'1 Q. III Lodo
— azul claro; pasta amarelada

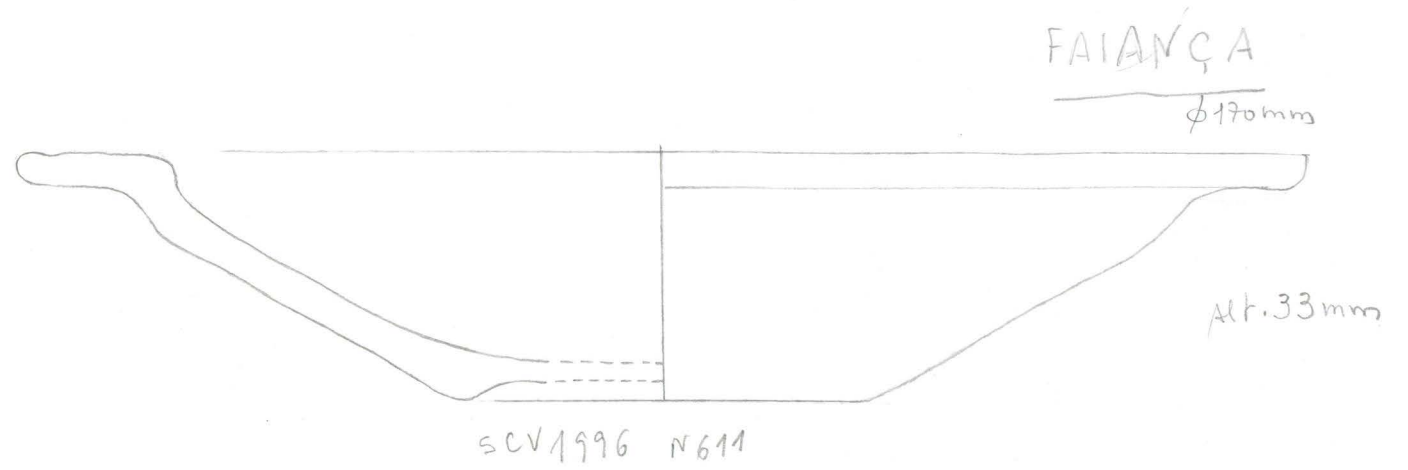

FAIANÇA
φ 170mm

Alt. 33mm

SCV 1996 N 611

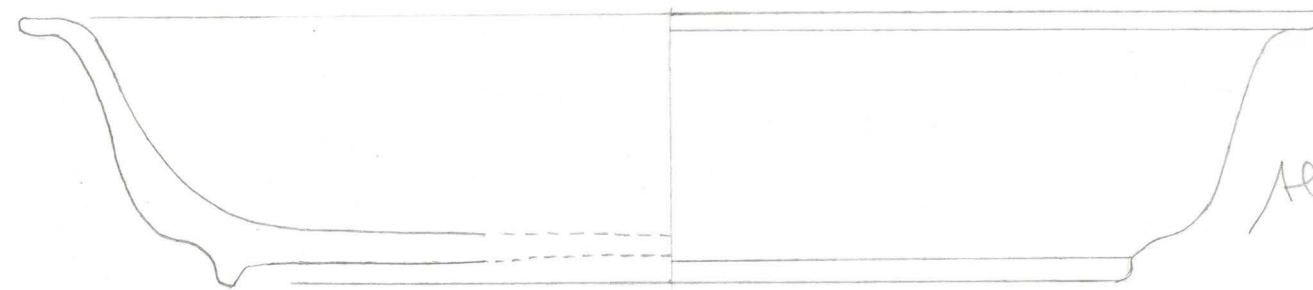

φ 172mm

Alt. 35mm

SCV 1996 A1 Q. I N° 686

φ 120mm

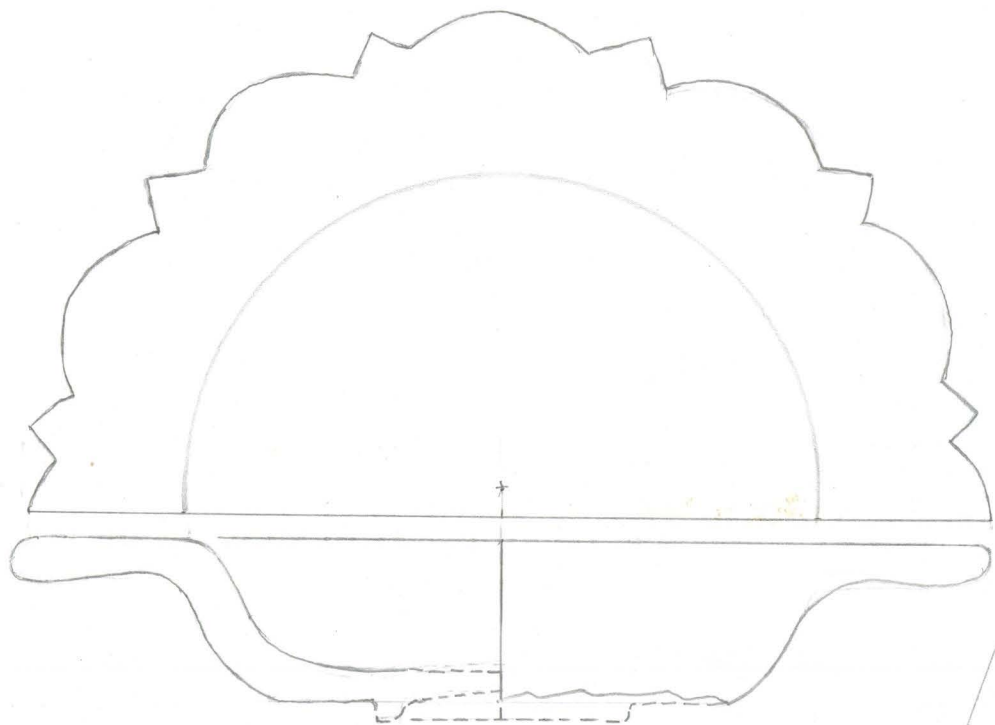

φ 128mm

30.2.96 SCV C°7 III nº 912

Pasta-
vidrado-

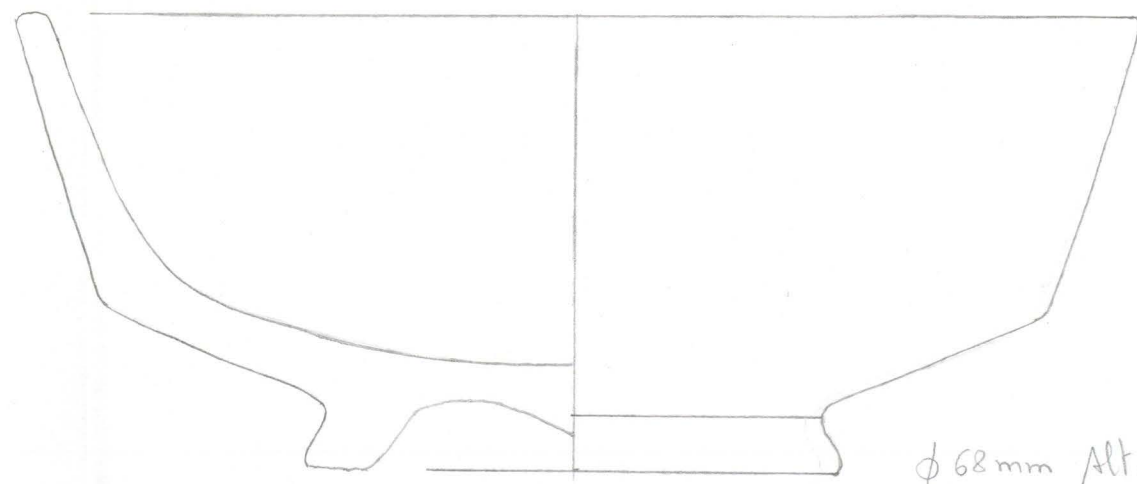

φ 146mm

φ 68mm Alt. 60mm

SCV 96 N° 633

292

22C6

ajul → tinta

pasto → 542

branco laranja

l: 12,9 cm
a: 4,4 cm

je ti

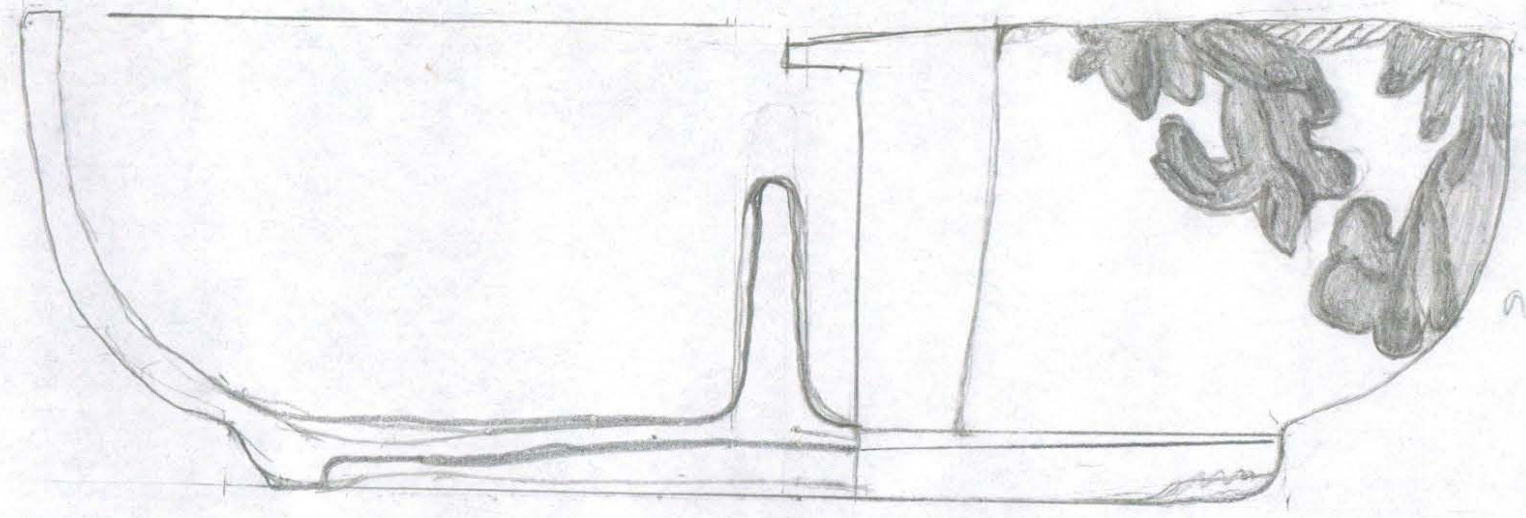

acanto

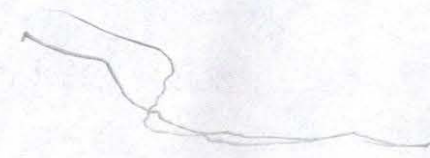



COMUM

18.6.96 A1 Q. I
Pasta vermelha clara
Decorações incisa

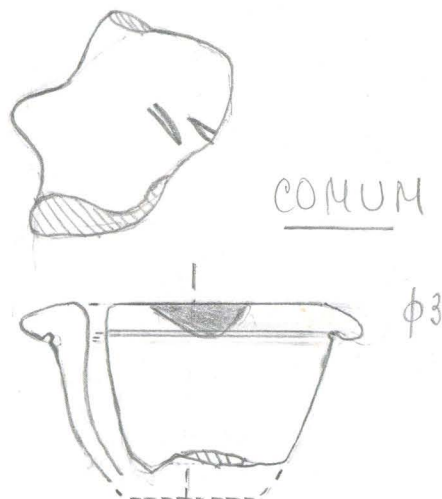

COMUM

φ36mm Pasta:
17.11.97 Engobe:
F? 1 I-III
Decorações incisa
6c

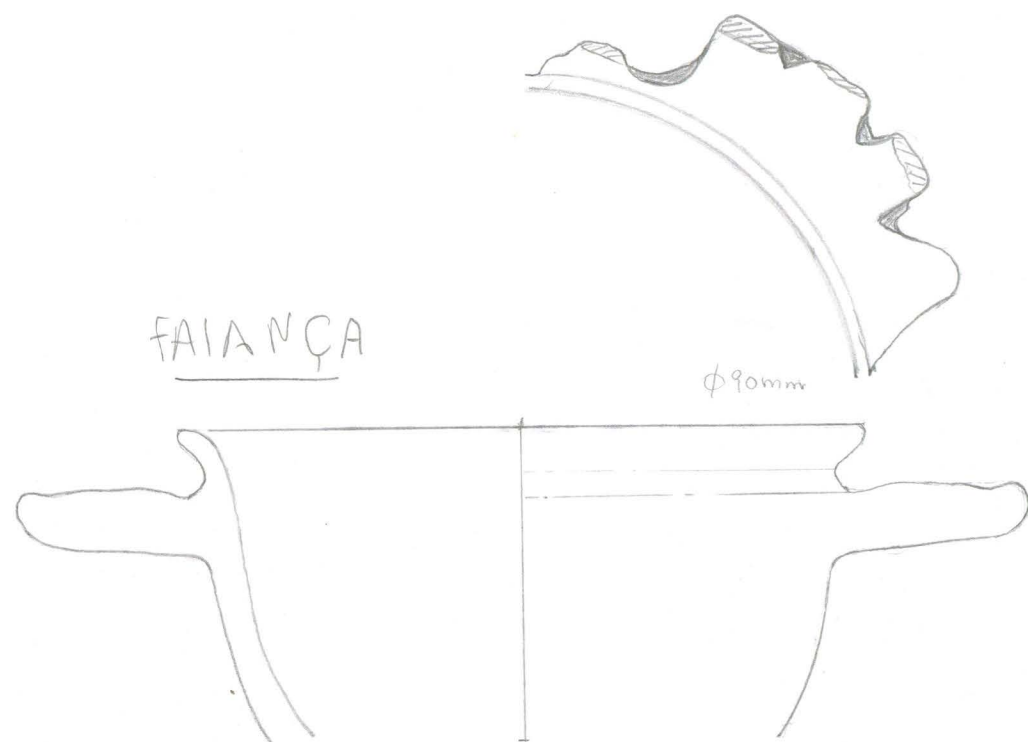

FAIANÇA

φ90mm

21.11.96 F3 III

N.B. →
Uma mesma
escudela?

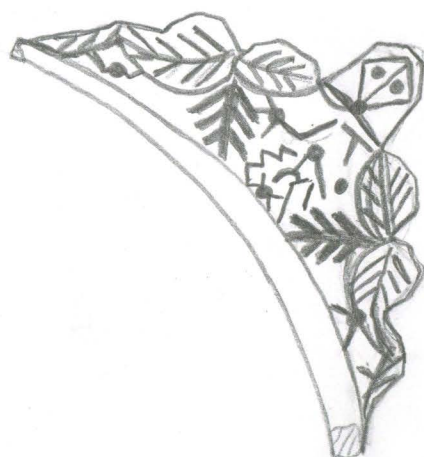

φ138mm

Comum



F' 2 Sond. 41 II Terra negra
Pasta -
Engobe -
Vestígios de fogo

6b

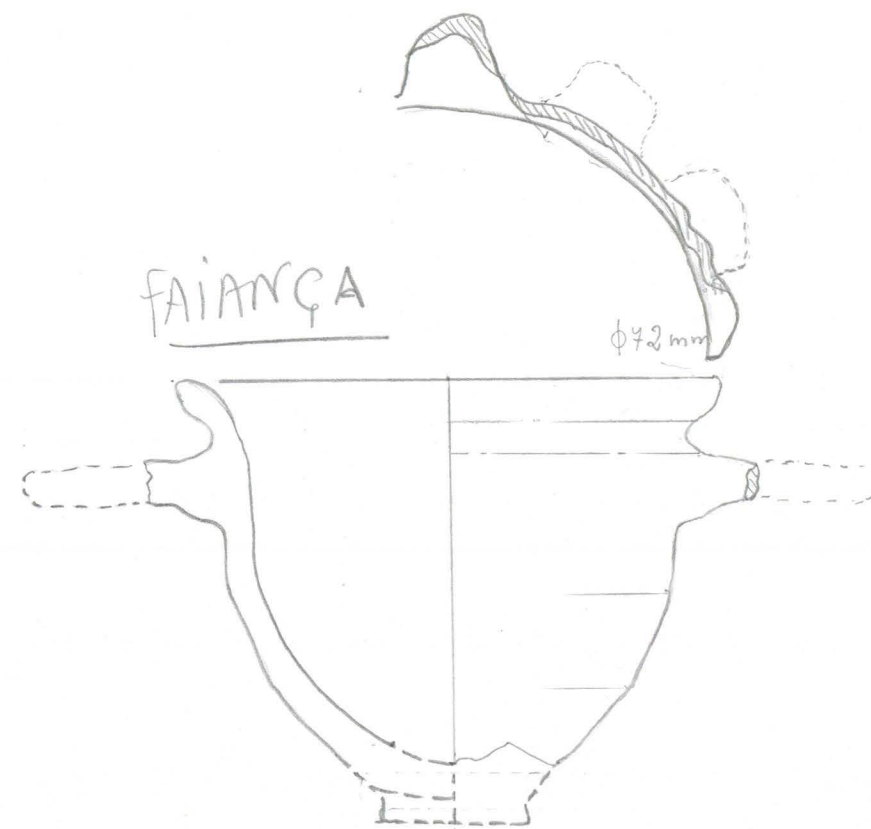

FAIANÇA

φ72mm

21.11.96 F3 III

Jais
jet-block

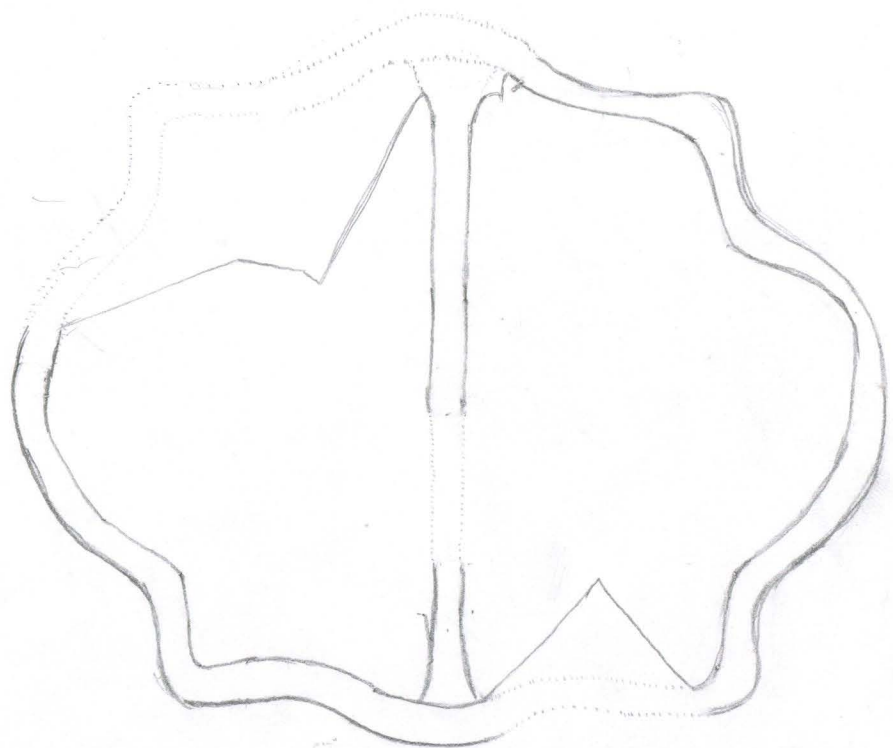
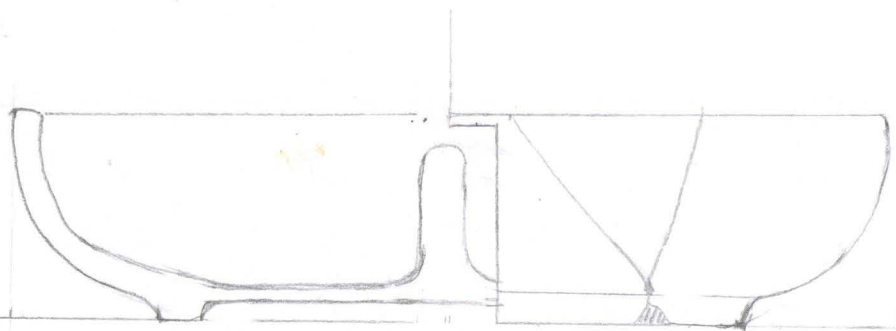
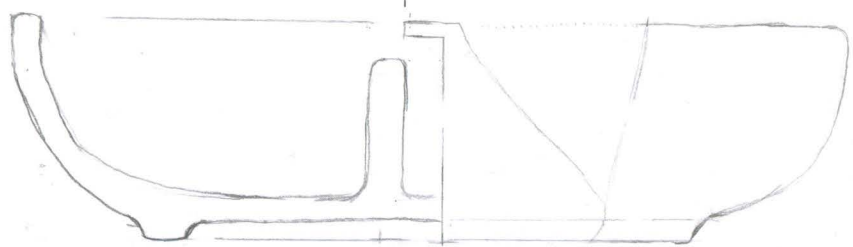

FF627

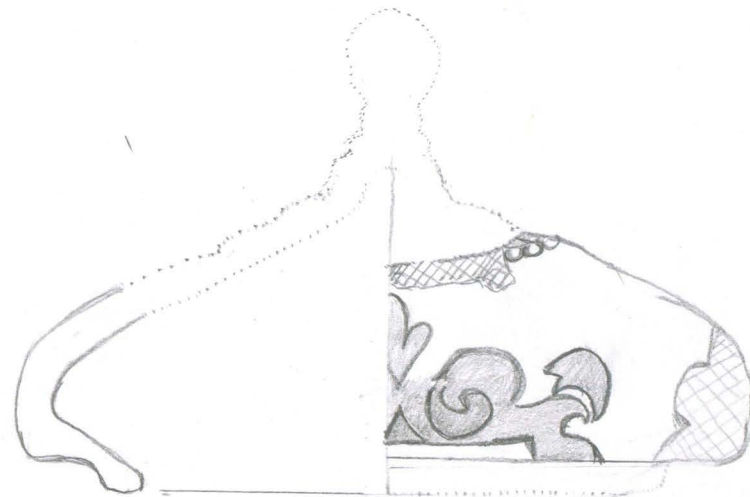

FF507

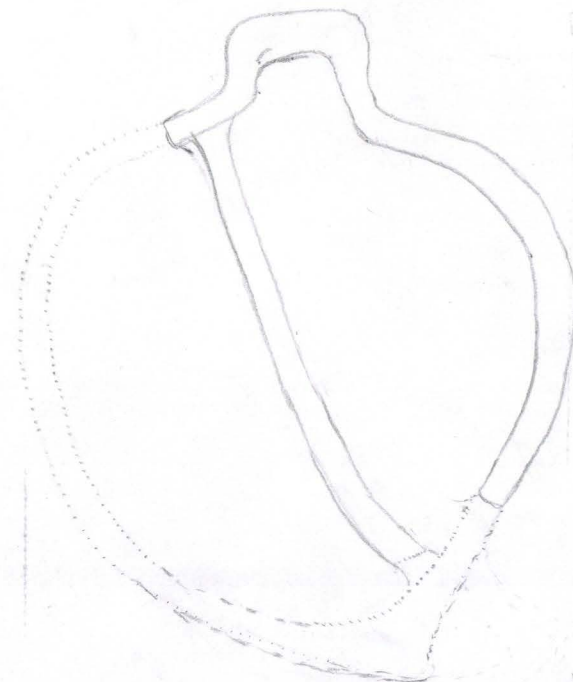
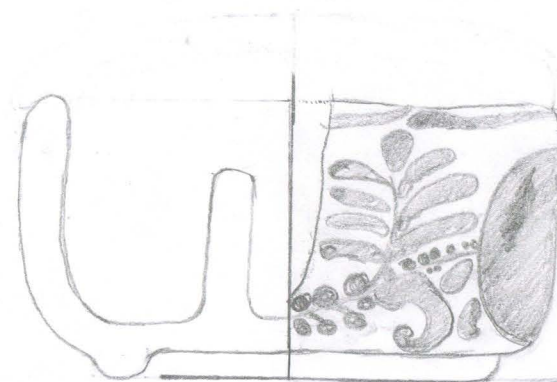

SCV. 21 FF1088

Fotos D: / FOTOGRAFIAS / Fotos Cerâmicas

esto q a GAIA
tem alguns

Outros espécimens em forma de coração FF1431. (Onde está?) (SCV 2004)
Tampa FF1502 pertence (?) a este espécimen (SCV 2005)

FF507

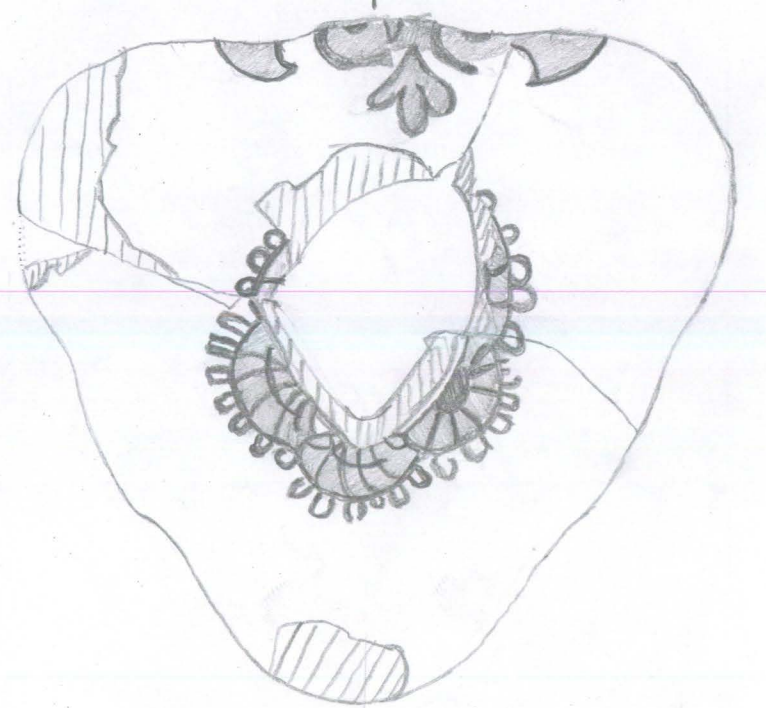

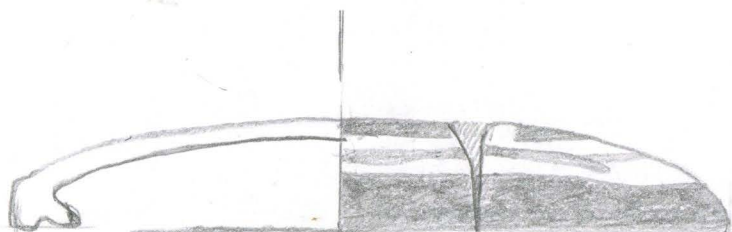
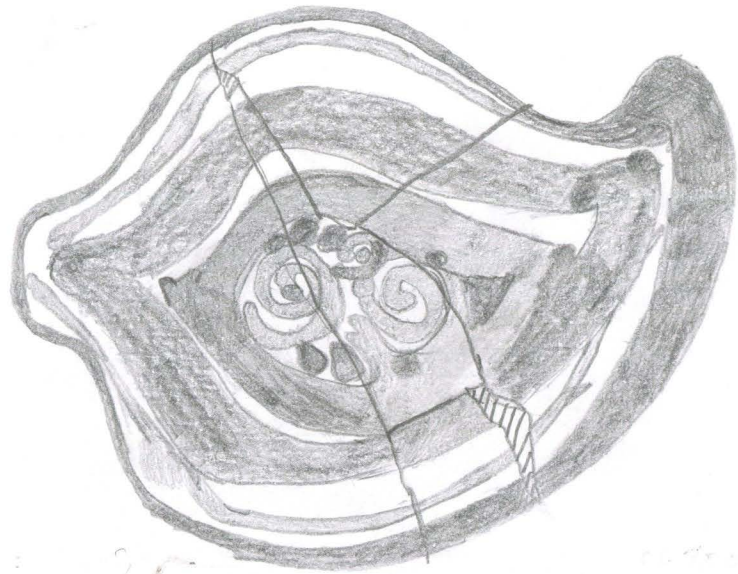

SCV 05 CIPA. Sond 46 FF 1502

azul (Meth. 2008)

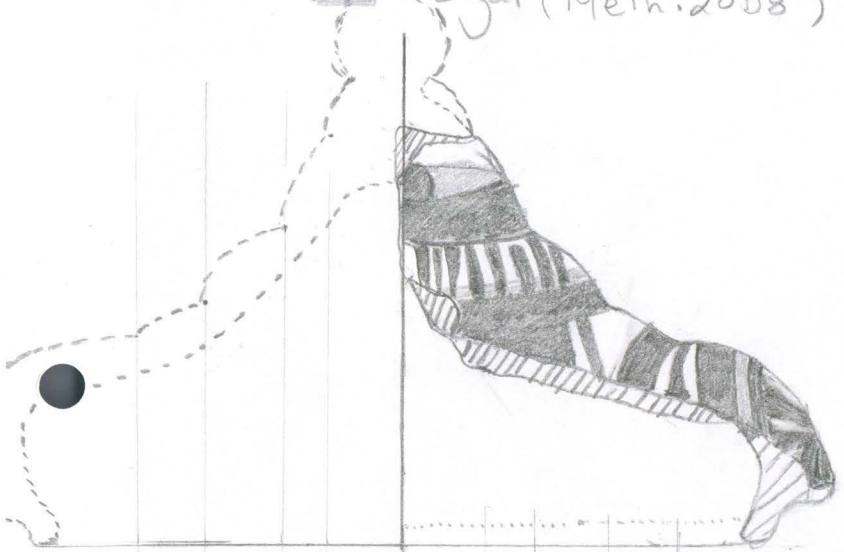

FF510

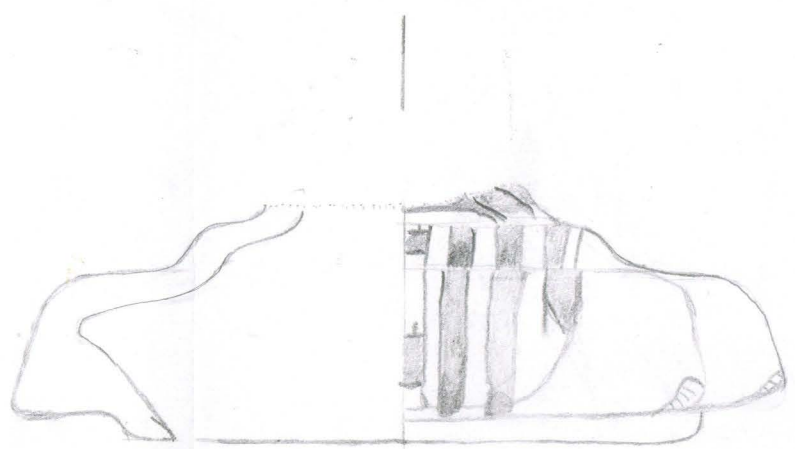
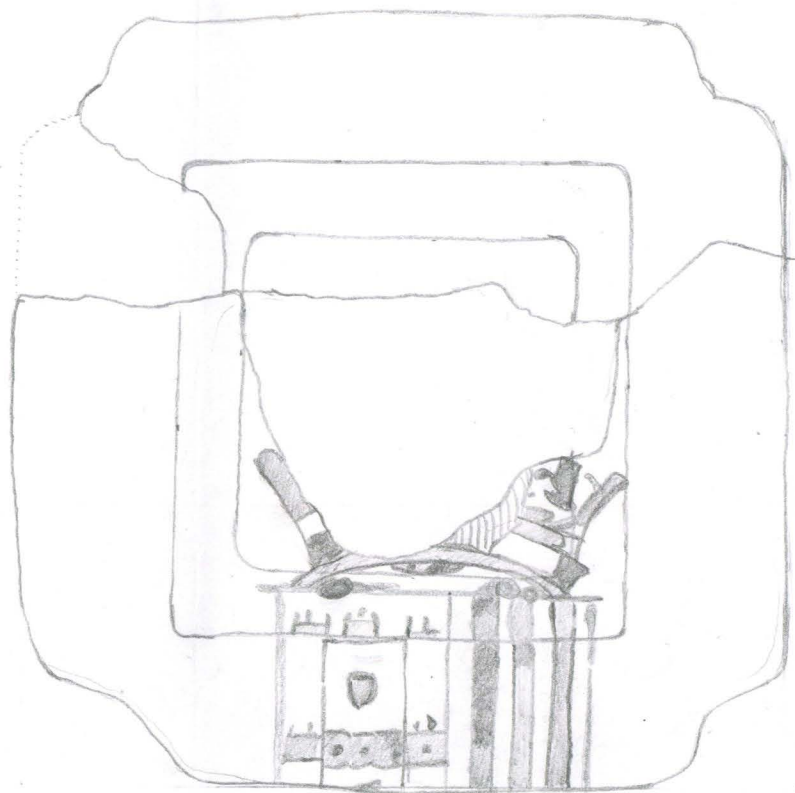

SCV FF 506

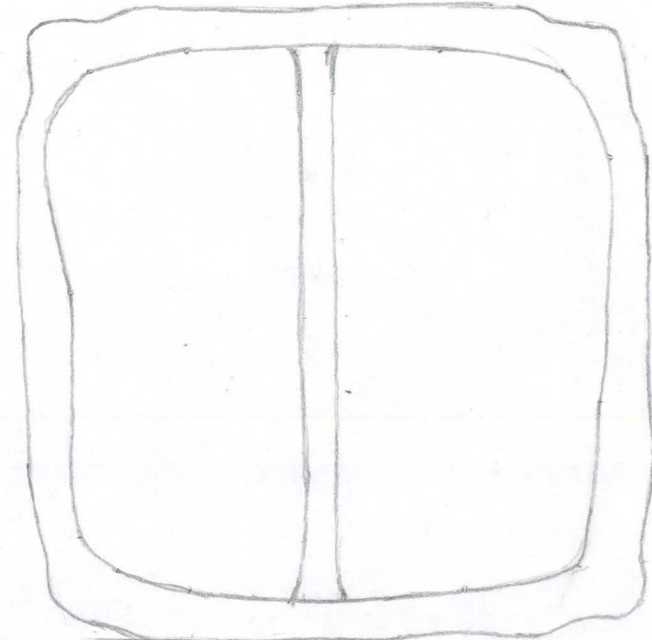
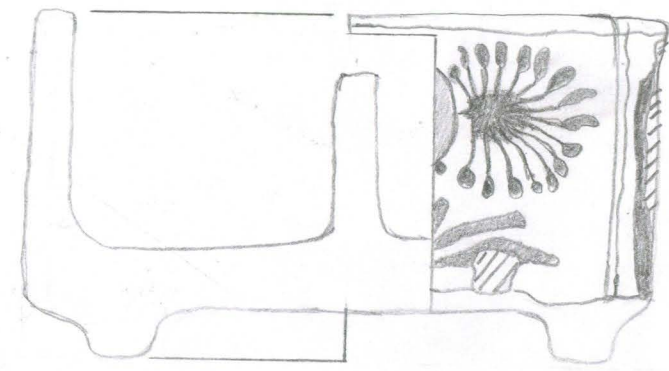
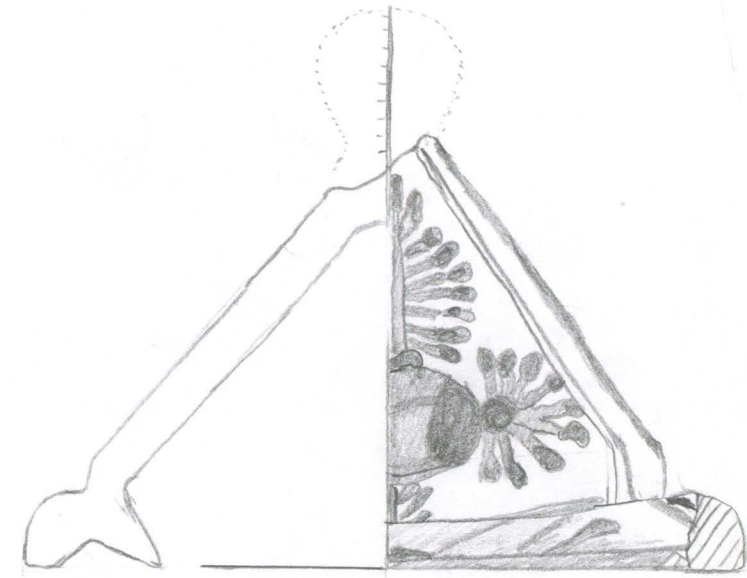

FF624

Jo' estas!

faianga

φ184mm

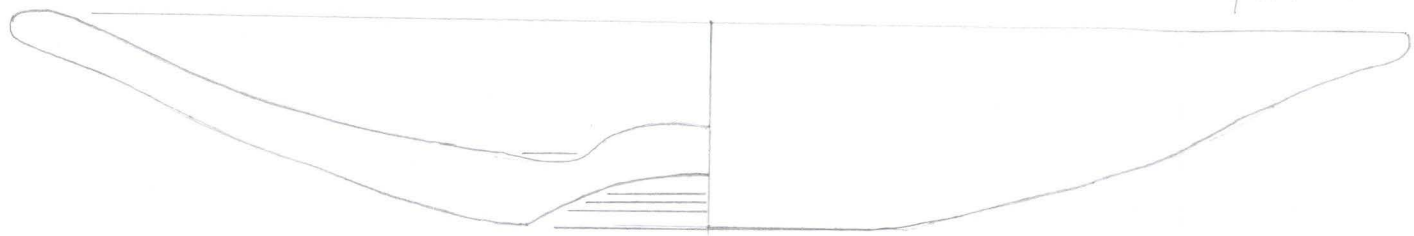

FF 1348
scv 99/12/17 F'3 Q. IV
Sond. 1A SALA A



cruc. incisa

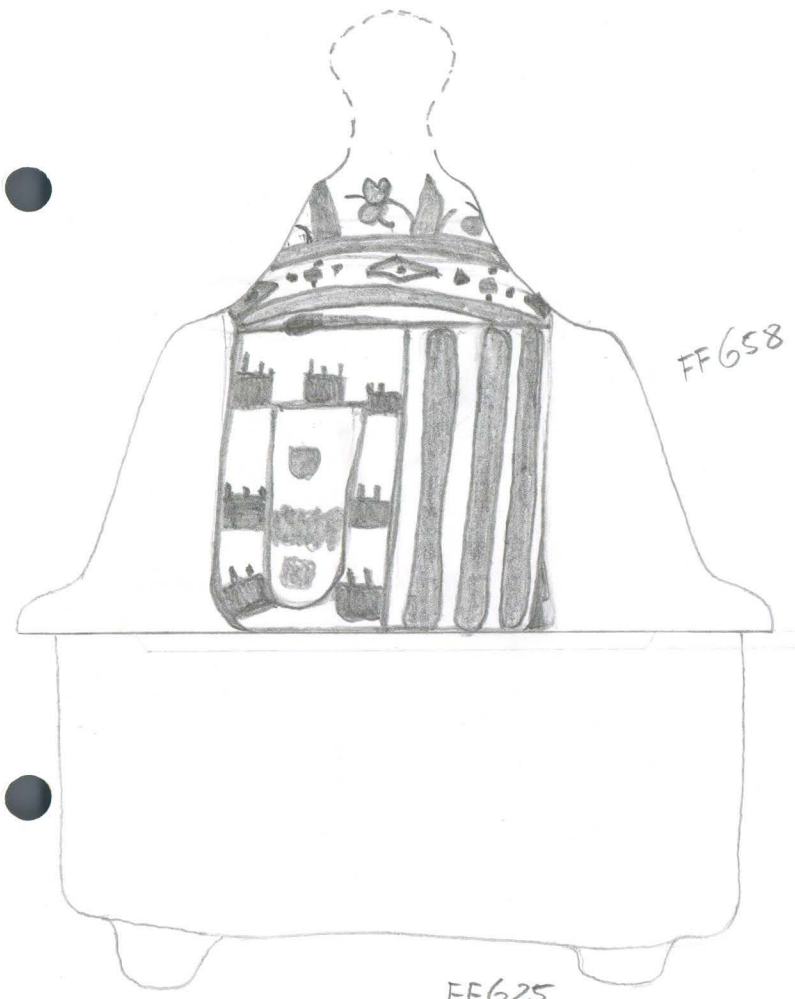

FF 658

FF 625

coxo.

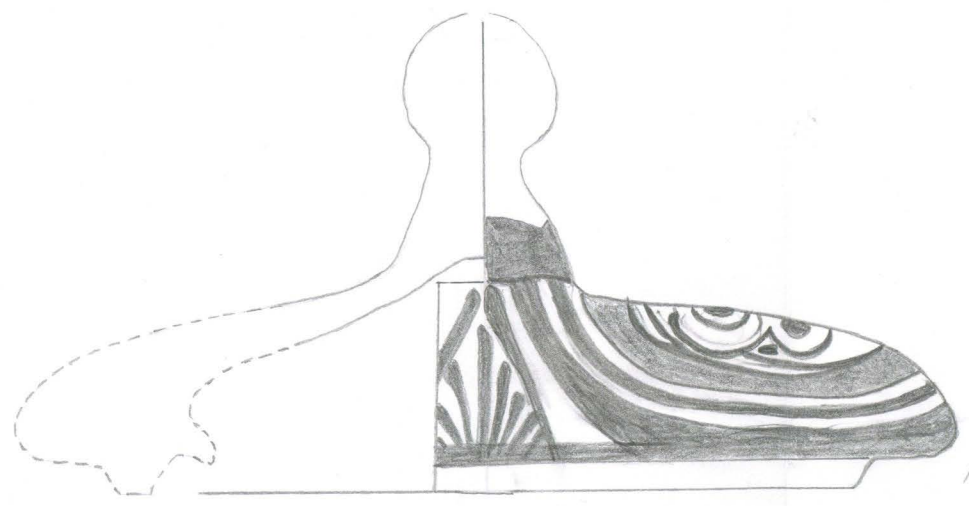

Alt. 63mm

FF 505

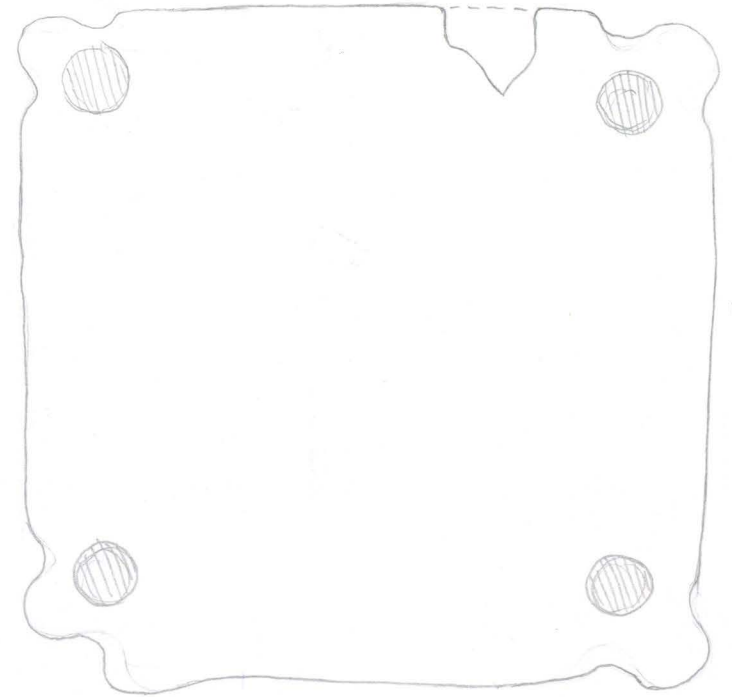
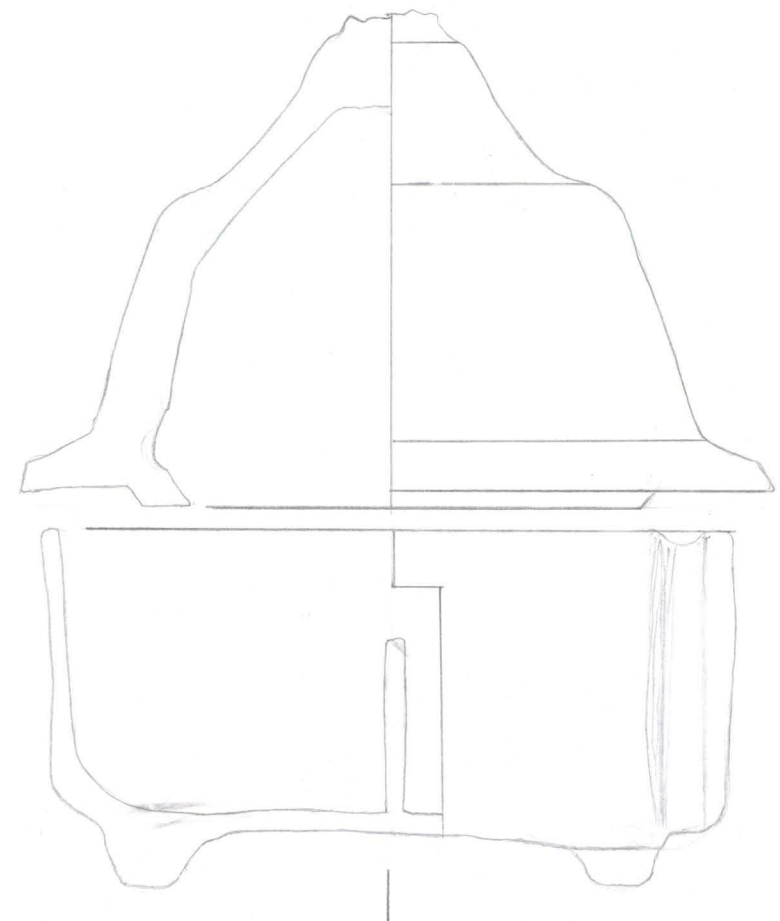
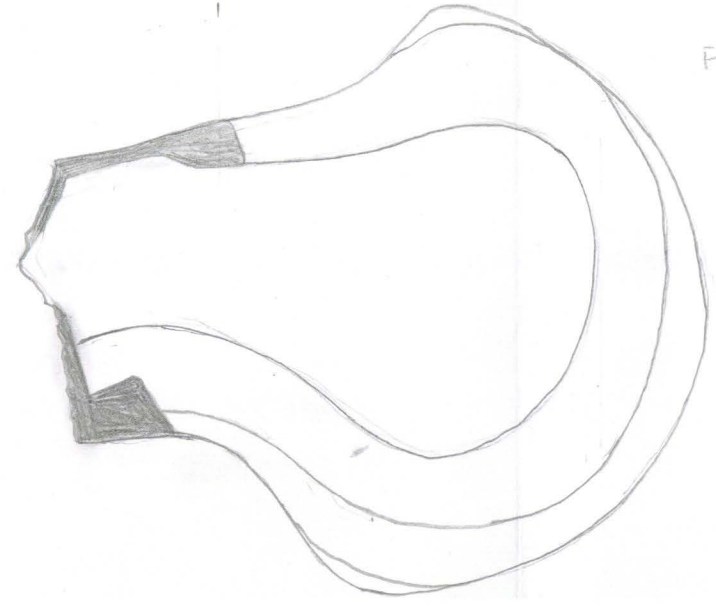

FF 1292

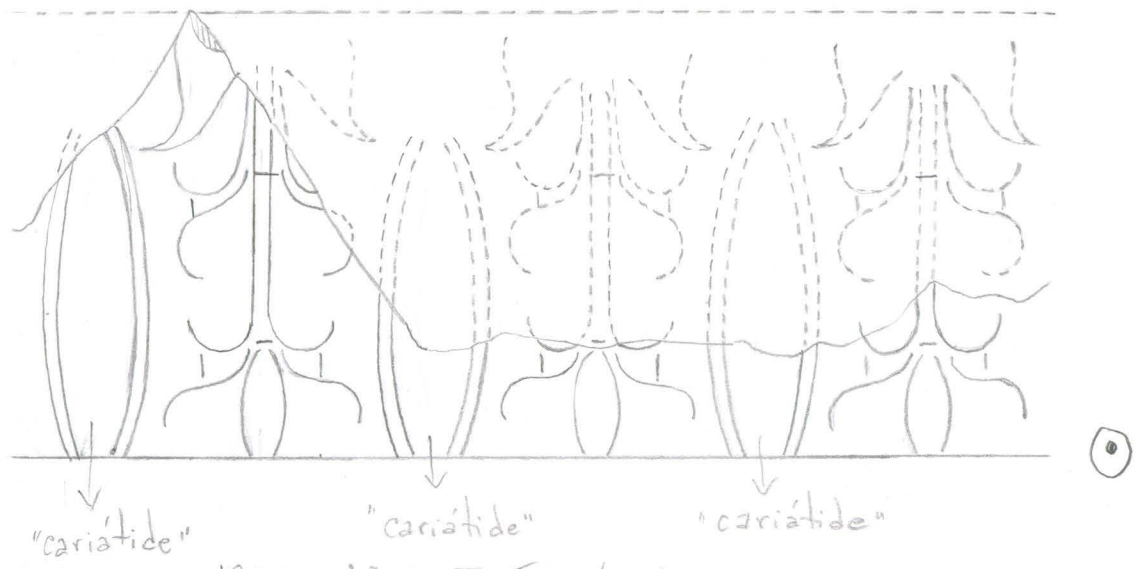

1996 c'5 Q. II Engobe laranja
 Desenho de fuma na folha ②
 Tipo pseudo-sigillatta

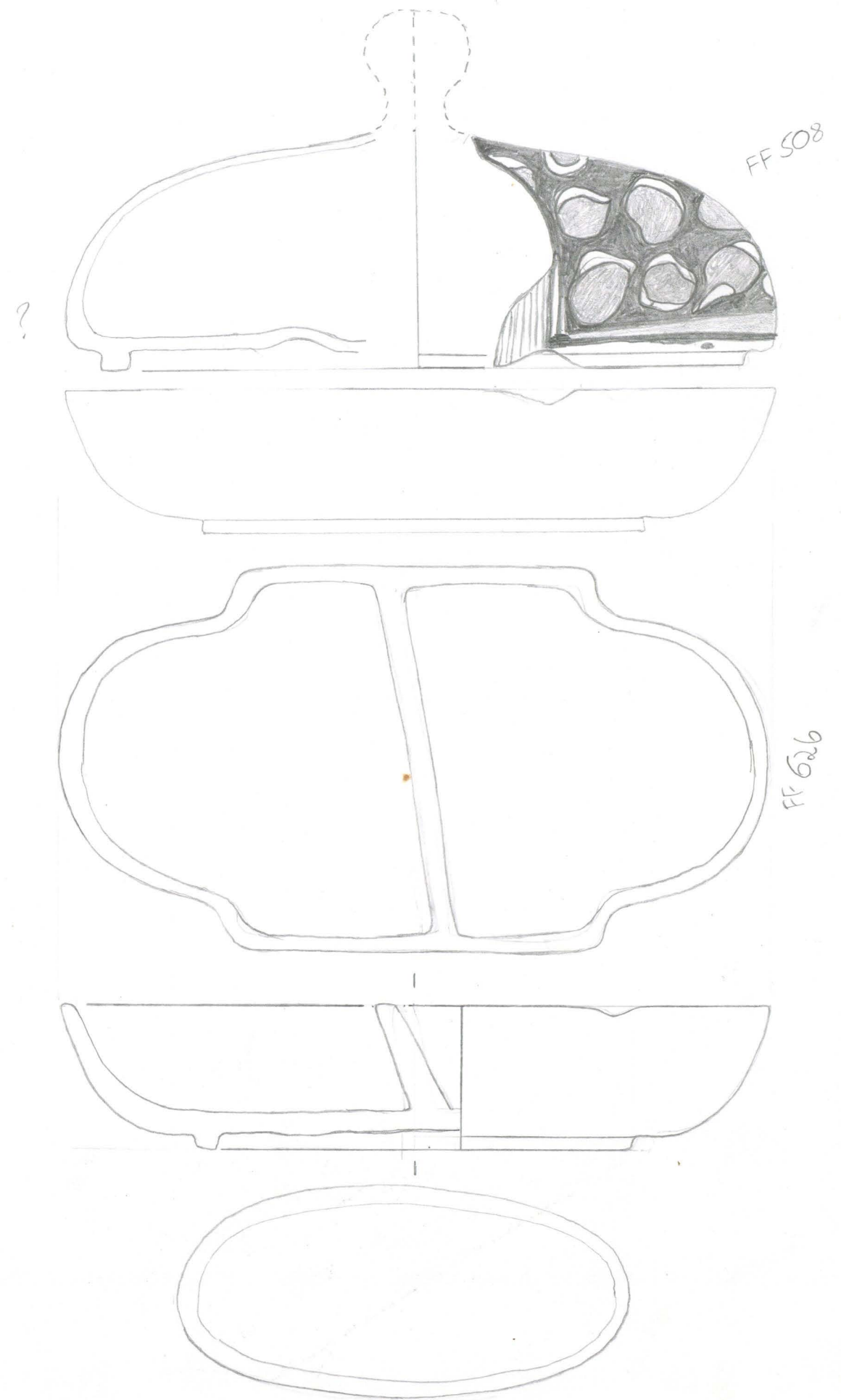

Faianga

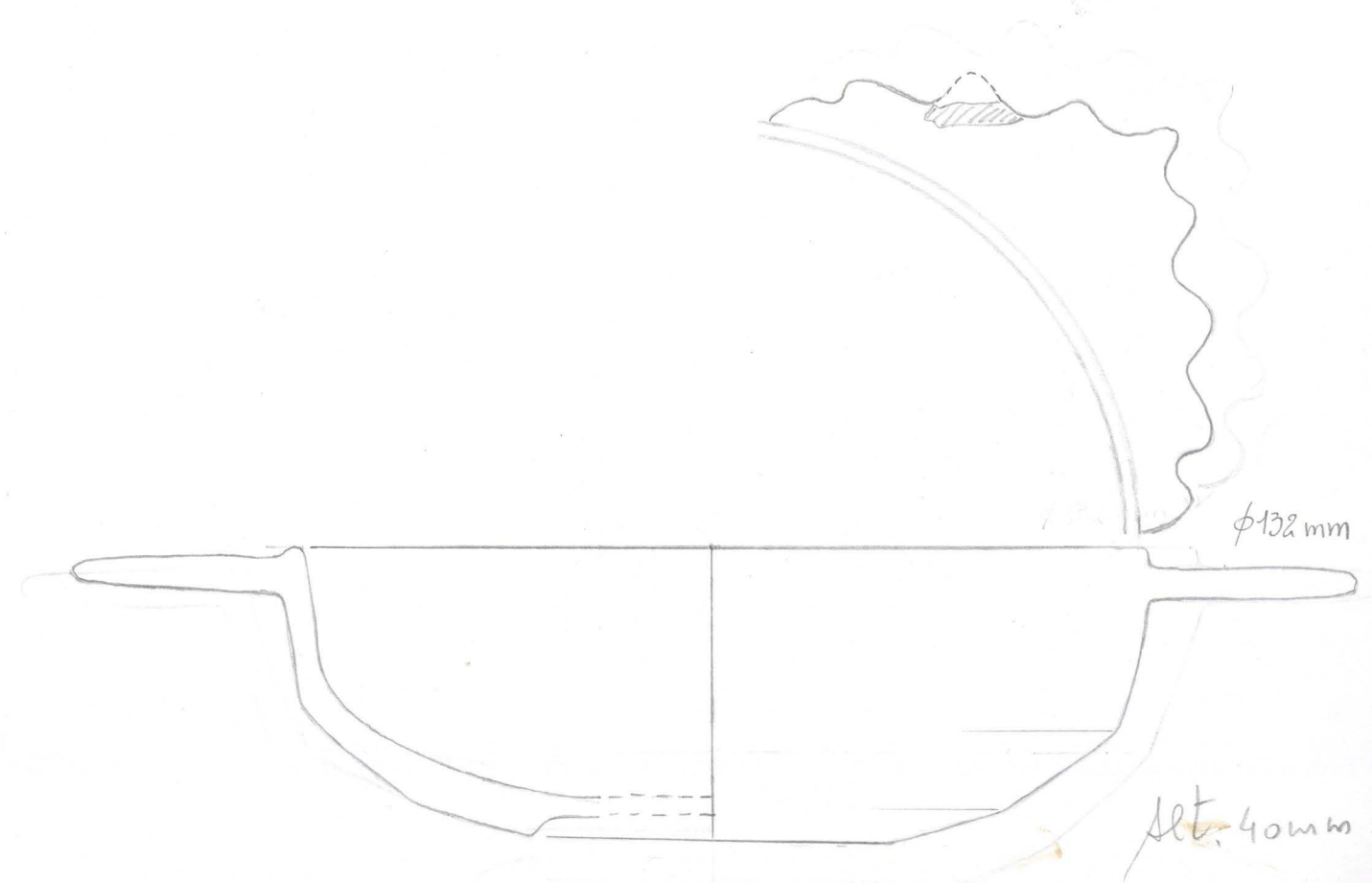

SCV 96 N.º 633
Faianga

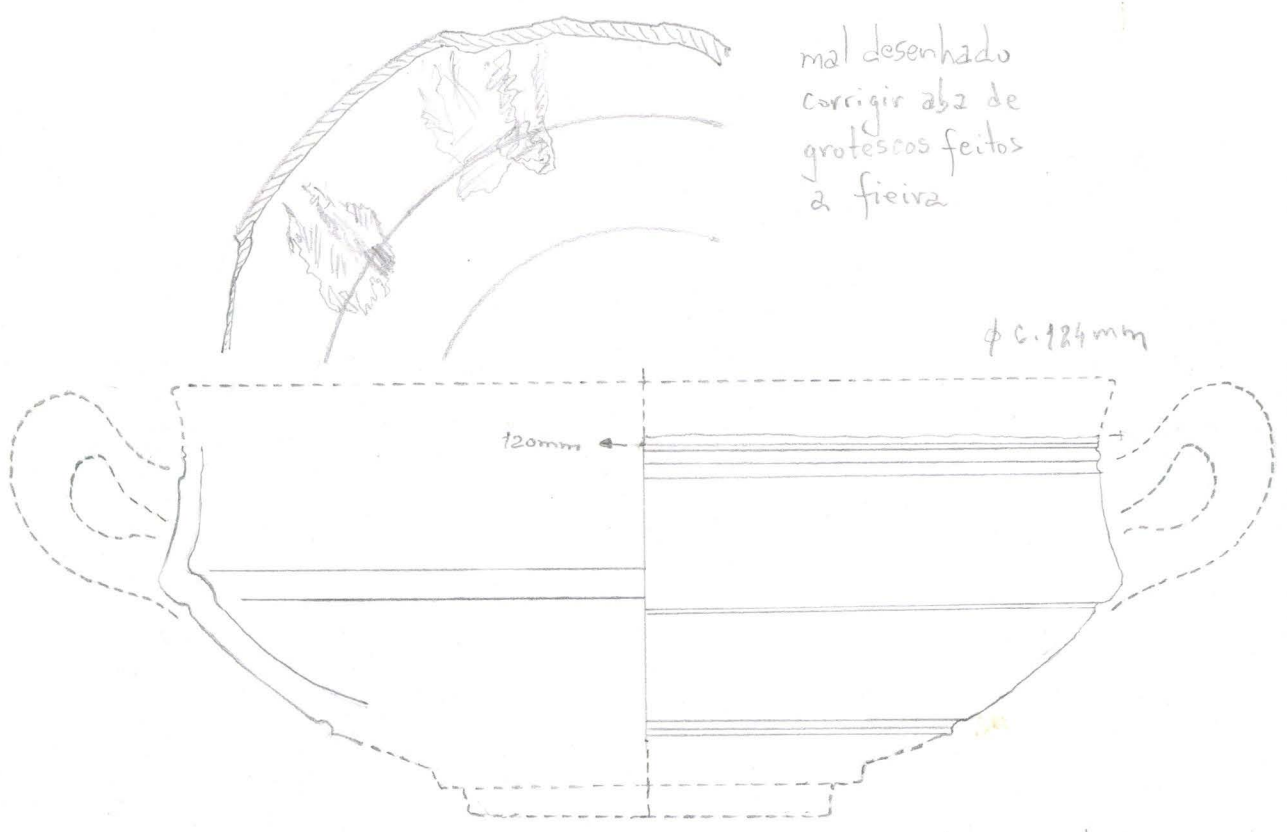

18.8.96 A1 I Sob enterramento C/engobe laranja claro

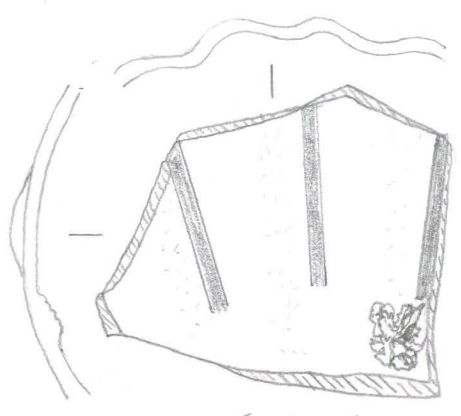

C'1 Q.I-II C/engobe laranja claro e brutesco
 Outro frag. com brutesco, mas de Opasta mais grossa, C/engobe mais avermelhada, em C'1 Q.I-II
 ■ - pintura a branco sobre duplo esgrafito

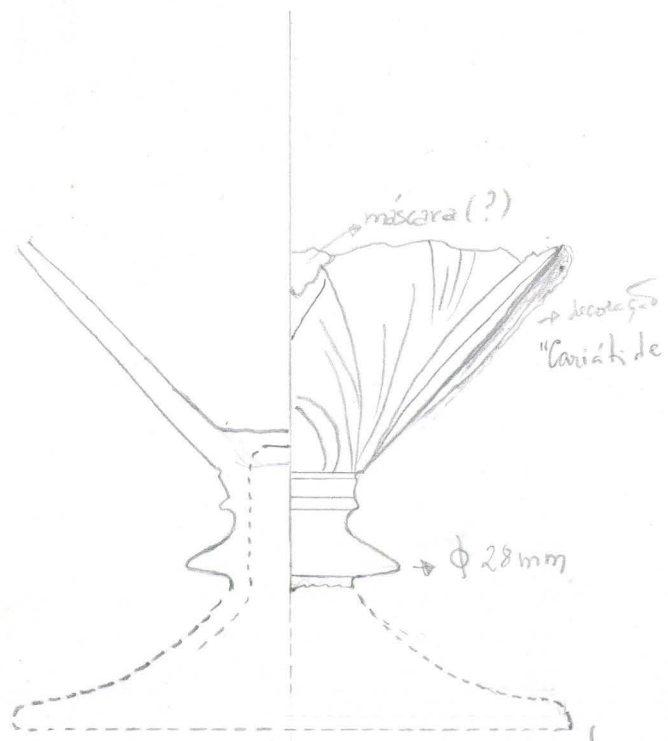

18.6.96 A1 I C/engobe laranja claro
 PARA outros fragmentos de copas, [drawing]

Cf. FOTOS 2720-2721 -> Incisões em pedras, c/engobe laranja claro - 29.11.01 - A1 II
 Cf. FOTOS 2720-21 - Base discóide c/engobe laranja - 18.8.96 - A1 I Sob enterramento

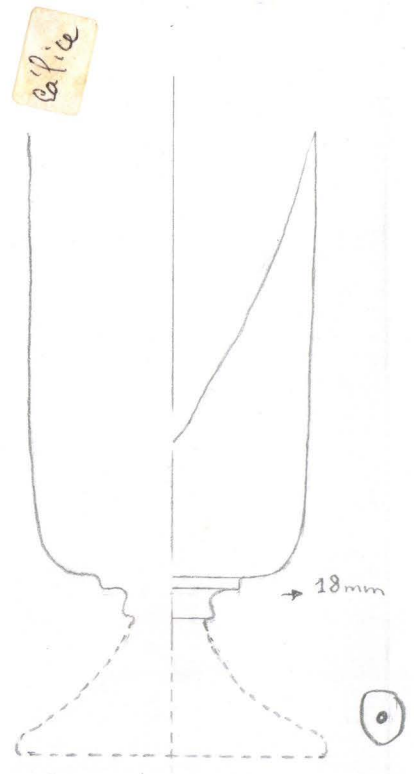

1996 C'5 Q. II
 Engobe laranja
 Decoração feita como as bandejas de prata com figuras levantadas em meio relevo. - Michaelis, p. 42
 Planificação do motivo - (3)

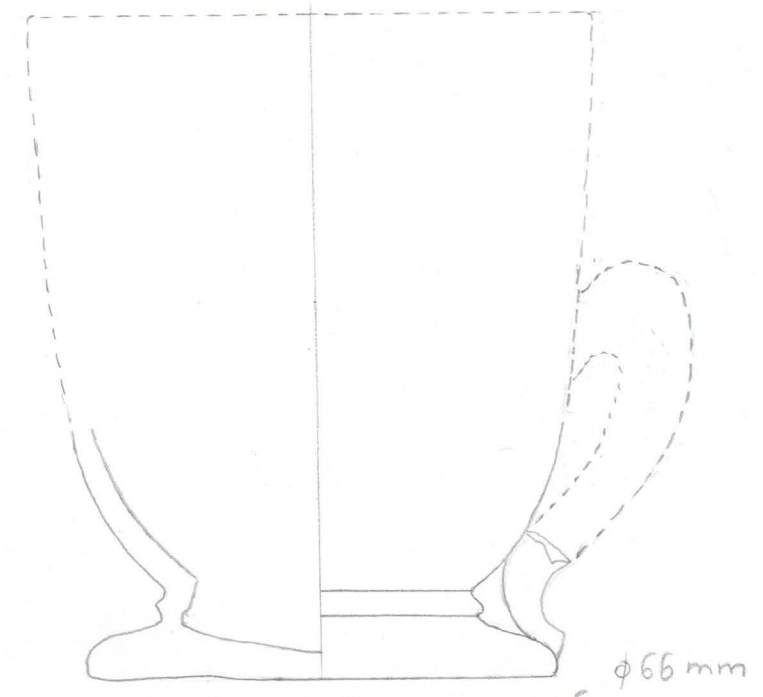

18.8.96 A1 I Sob enterramento C/engobe laranja claro

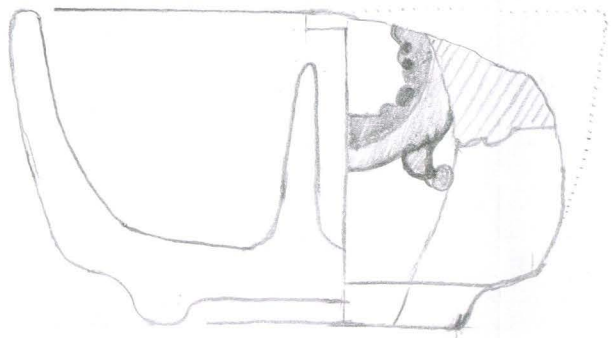

Jo 1201

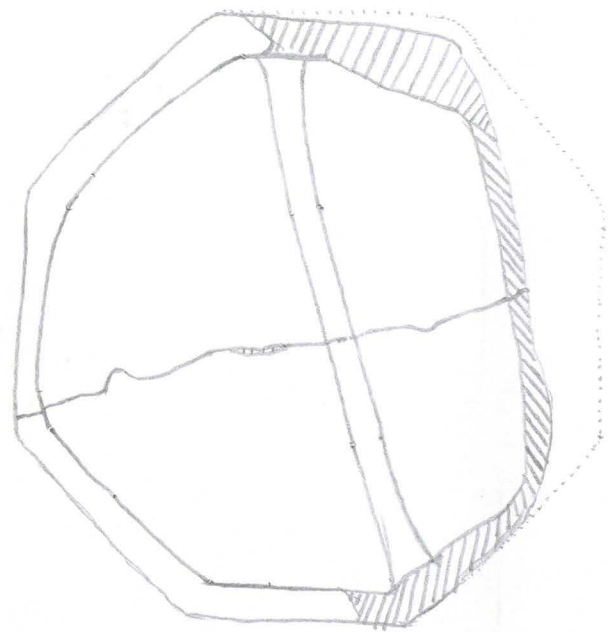

SOV FE 1299

CERÂMICA COMUM VIOADA A VERDE
GRUPO DE PASTA BRANCA

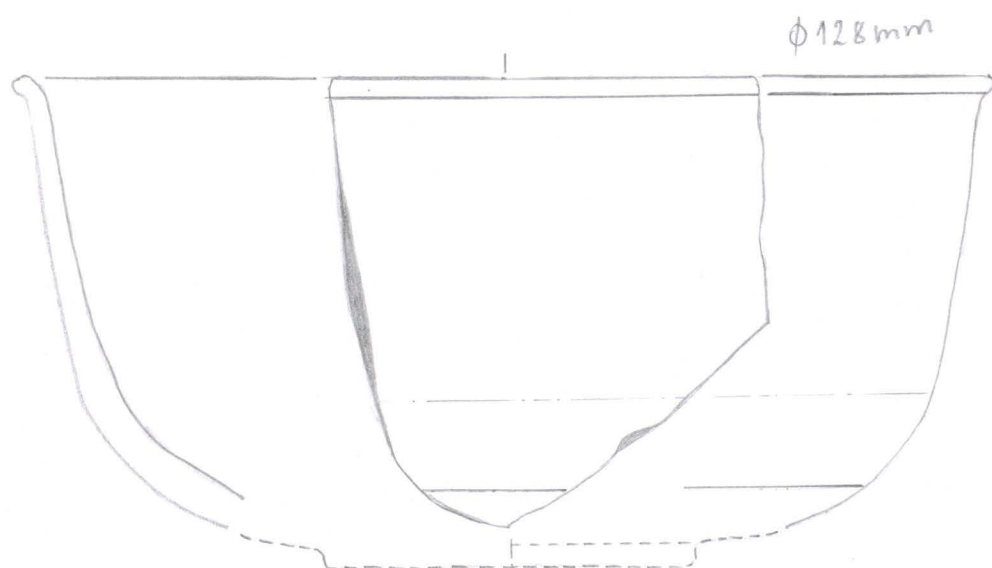
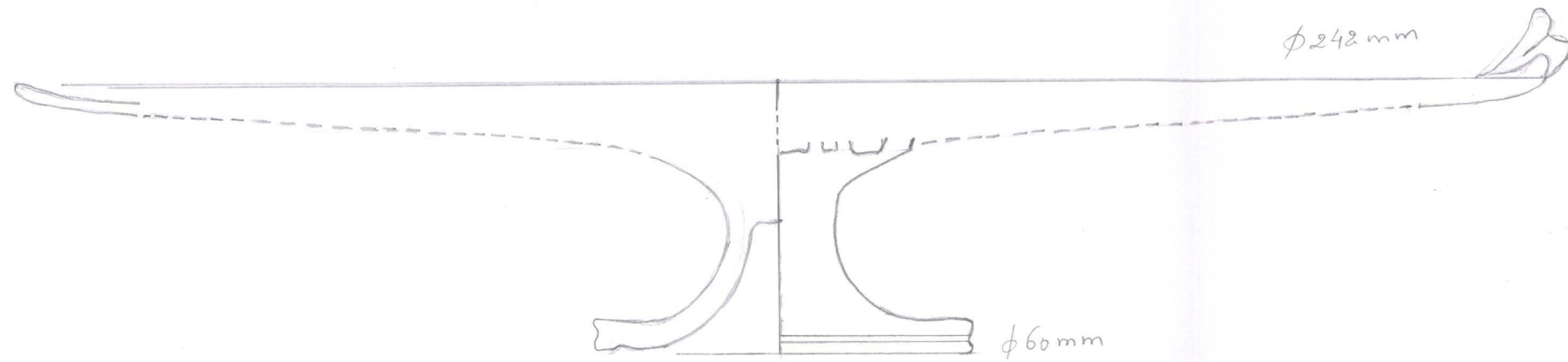

B'1 Q. II 2003.??
 Pasta branca Methuen —
 Vidrado verde Methuen —

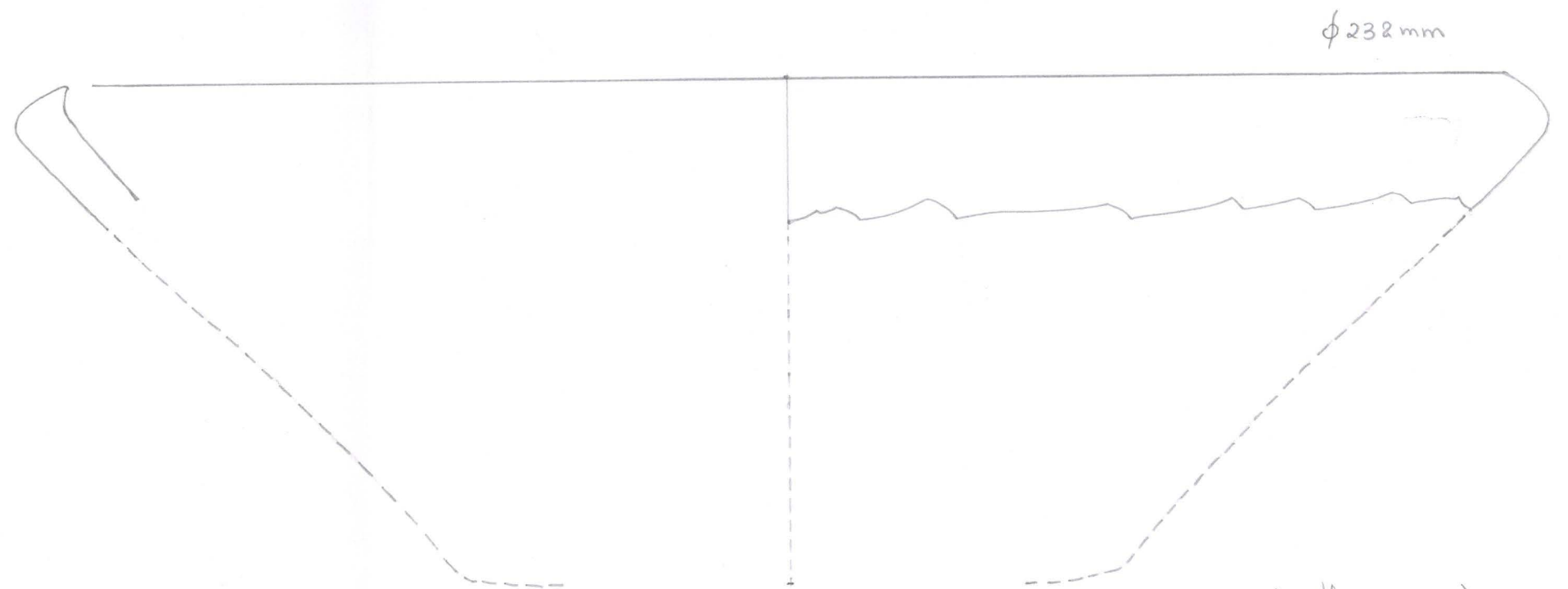

B'1 IV Pasta branca Vidrado verde (Meth. —)

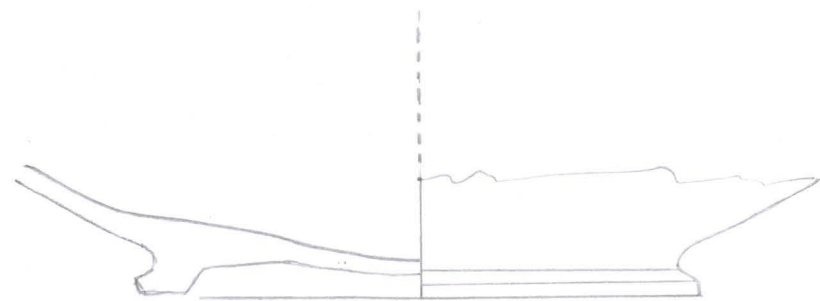

20.10.97 F'3 V φ74mm
 Pasta branca Methuen —
 Vidrado verde Methuen —

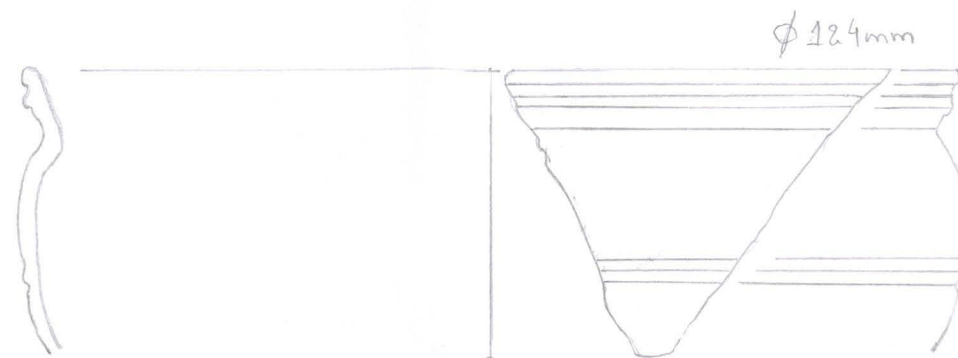

1996 C'1 Q. I-III Vidrado verde
 (Meth. —); pasta branca (Meth. —)

afesor linder de metaco!

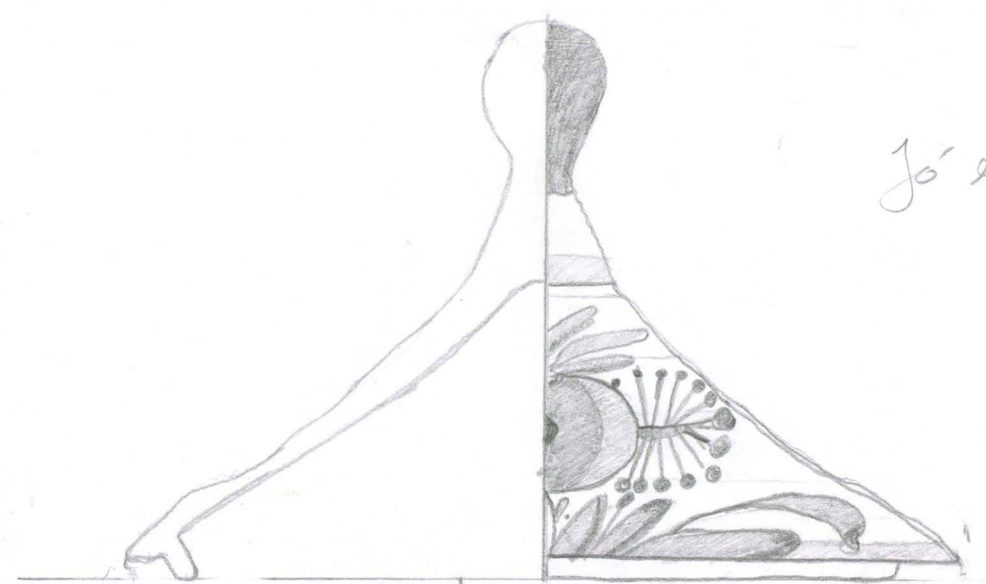
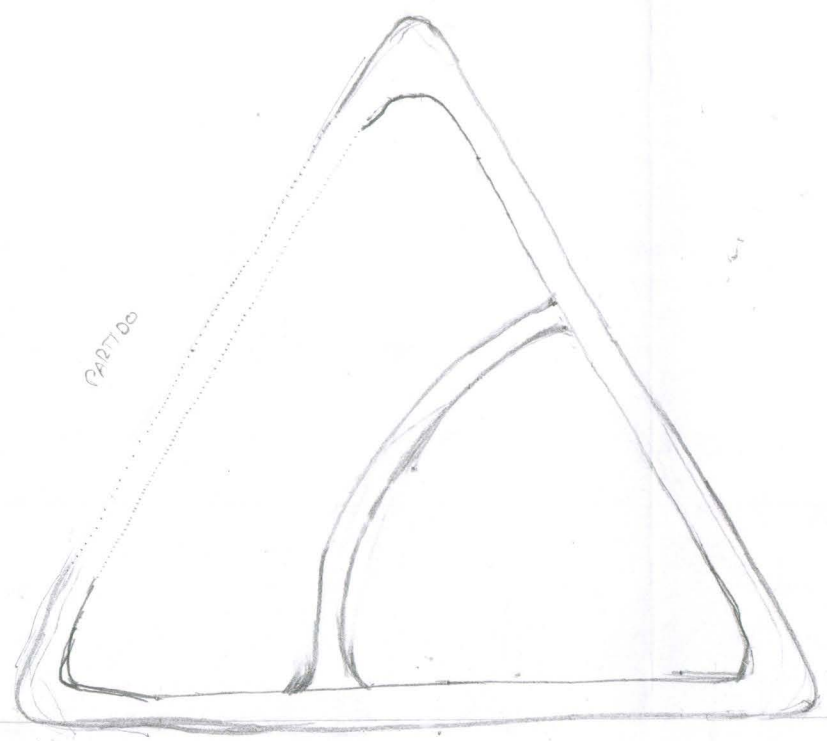

Jó esto!

FF470

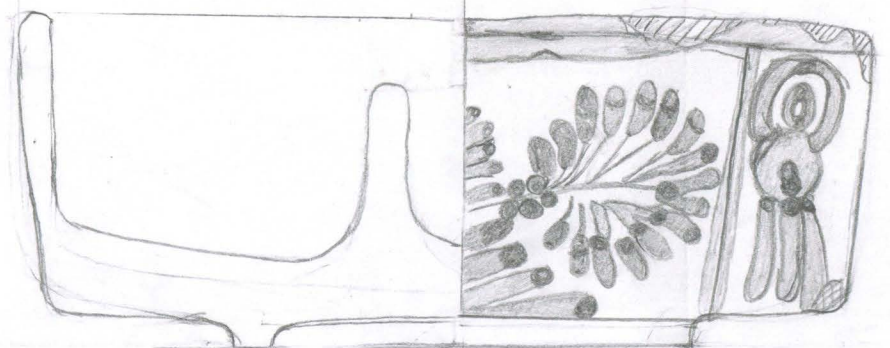

— - - gulo claw

SCV 97/2/3 F'1 PII Lodo
N-41 FF1296

fases/etapas - 1: - media o fondo - $95\text{mm} \div 2 = 47,5\text{mm}$

FF 292

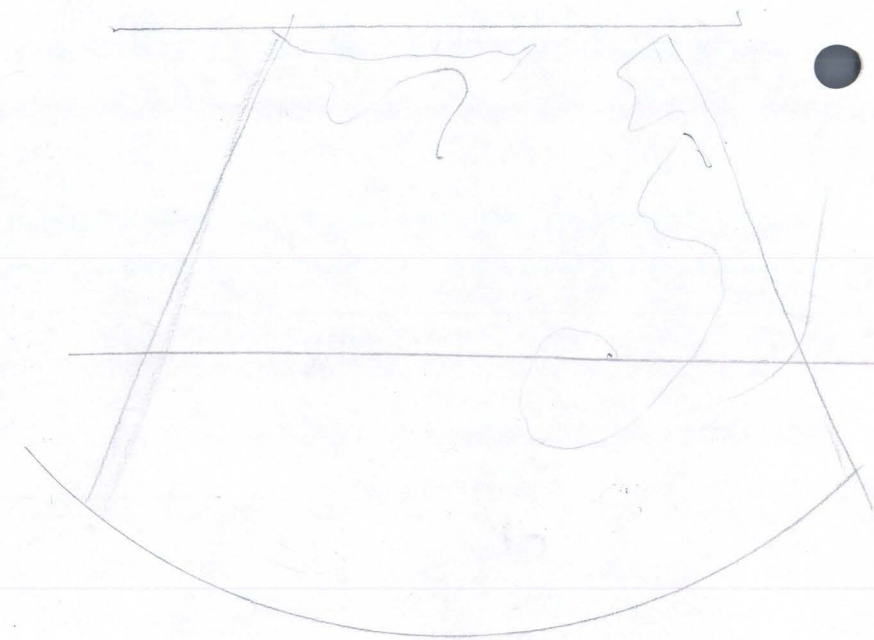
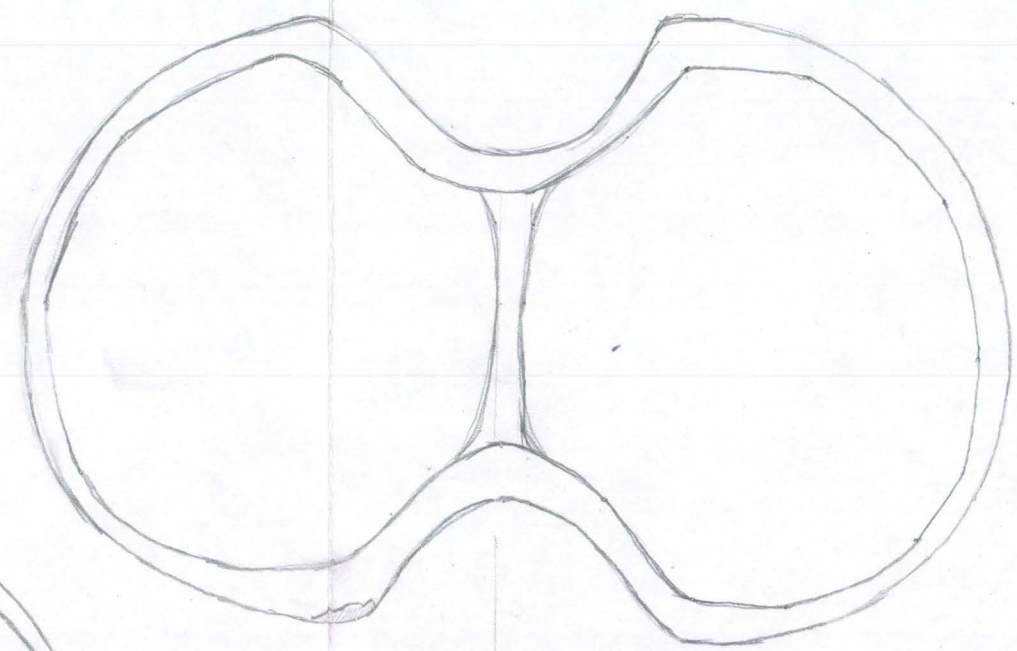
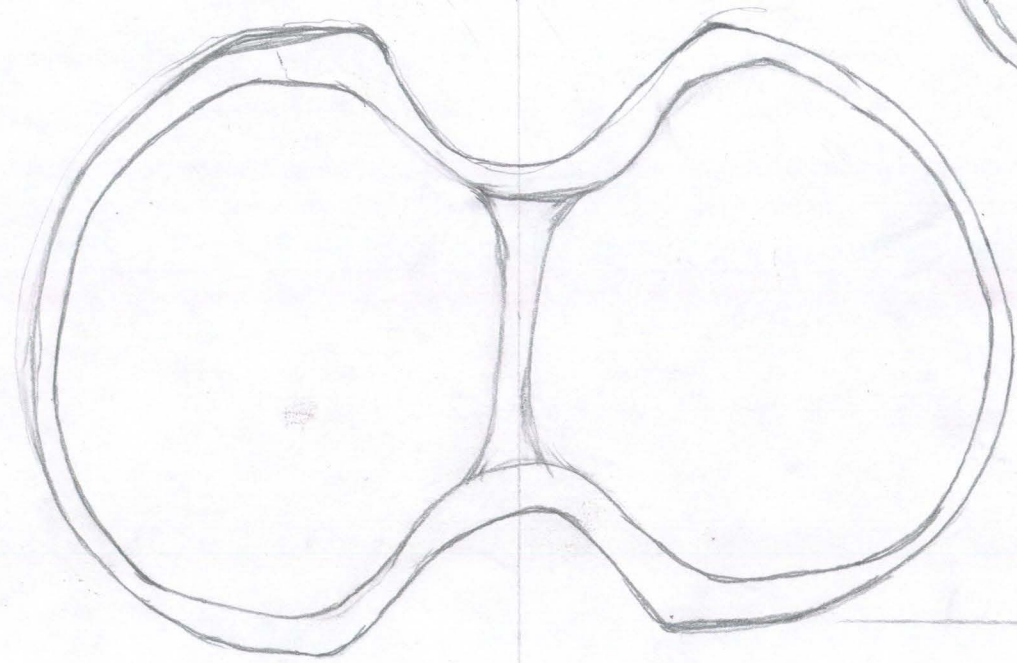

jó tui!

←→ 95mm



ENGOBADAS
A MANEIRA DAS SIGILATAS

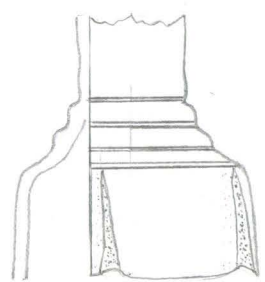

12.12.96 D² I Lodo
frangincho?

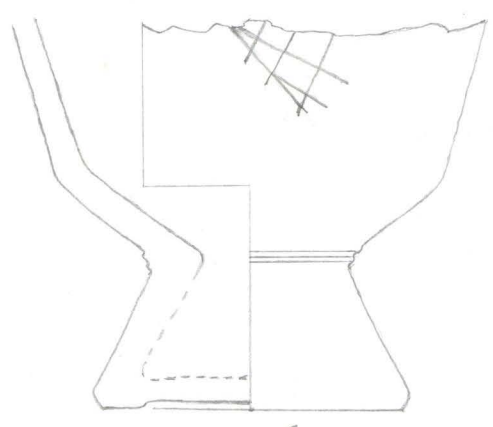

A11 @. IV

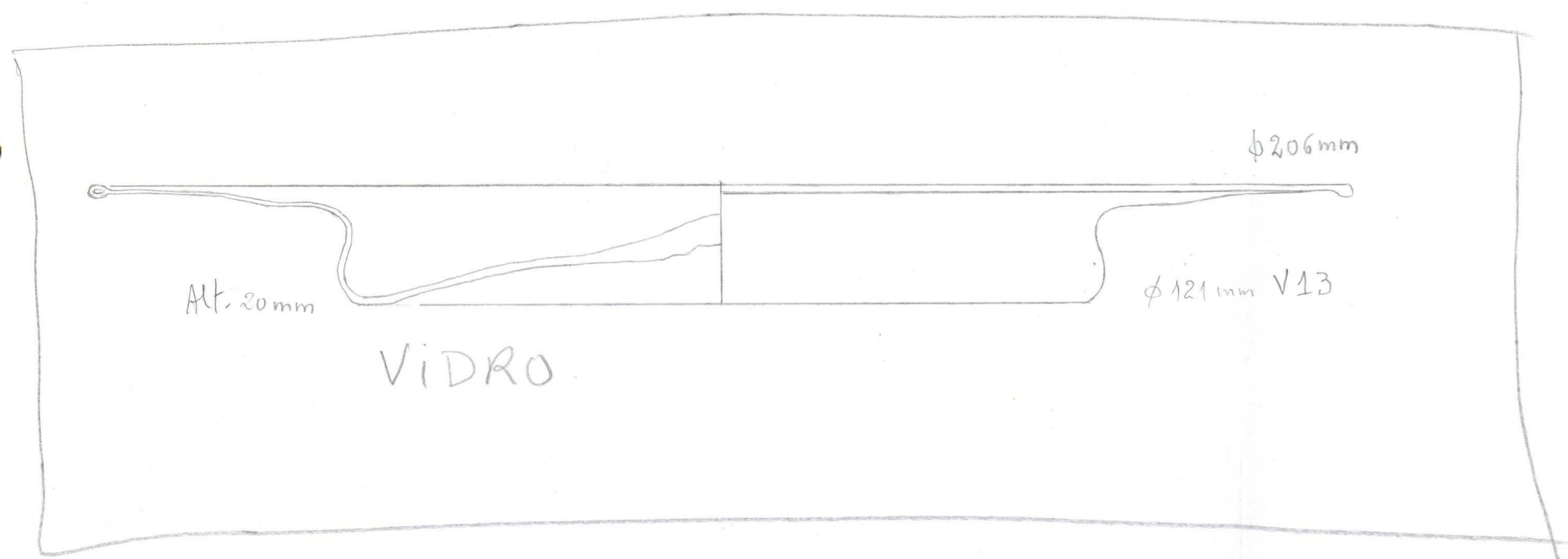
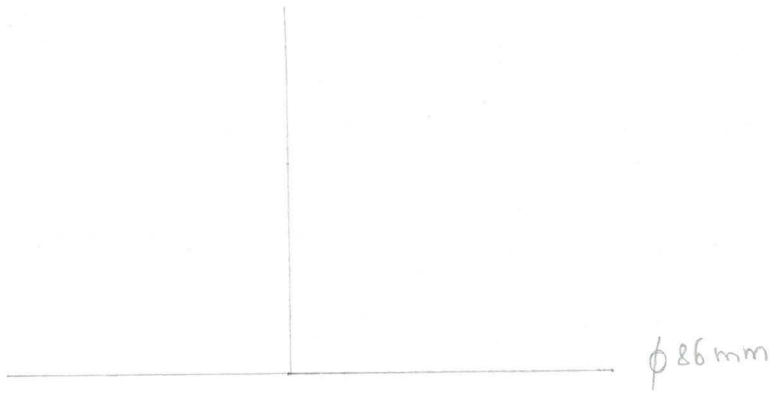

cerâmica engobada - pseudo-terra sigillata

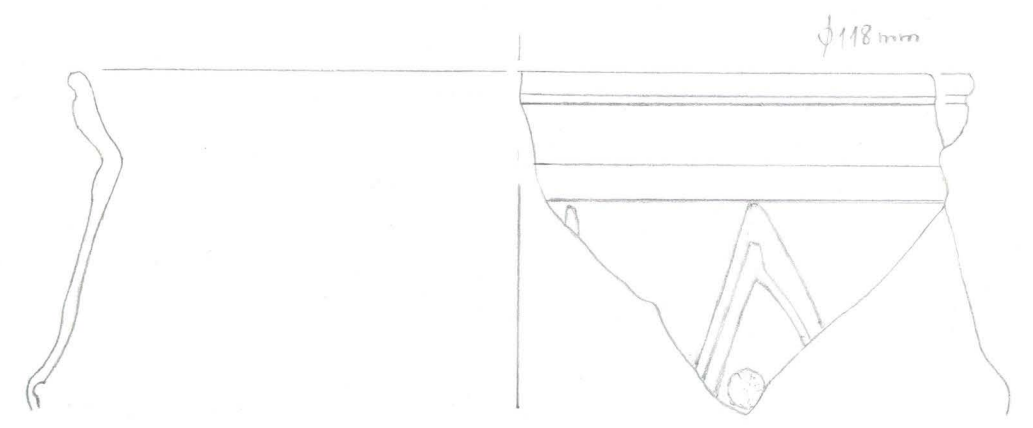

30.11.2005 e'1 Q.I Sond. 46 cipa Terra negra

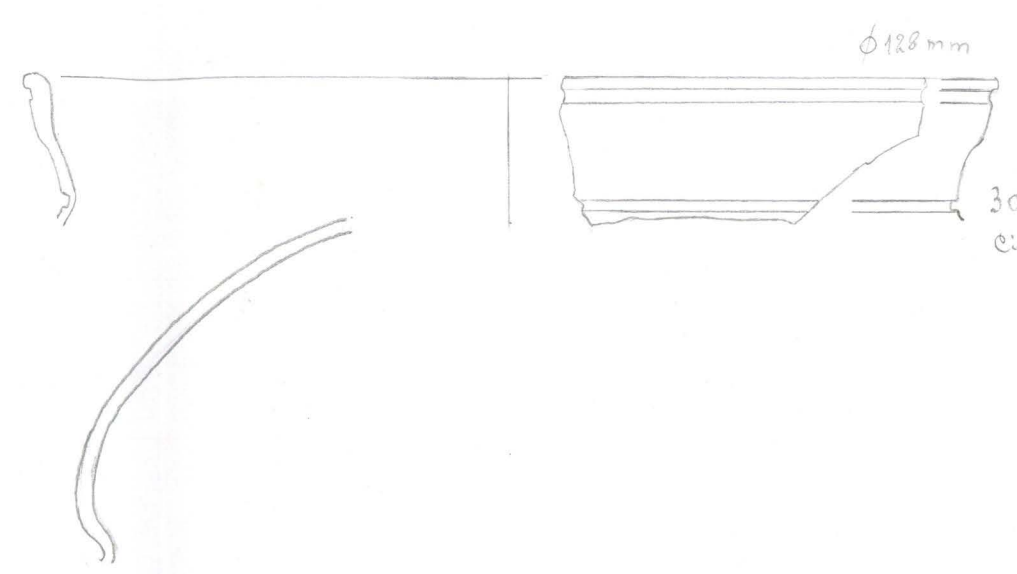

30.11.2005 e'1 Q.I Sond. 46
cipa Terra negra

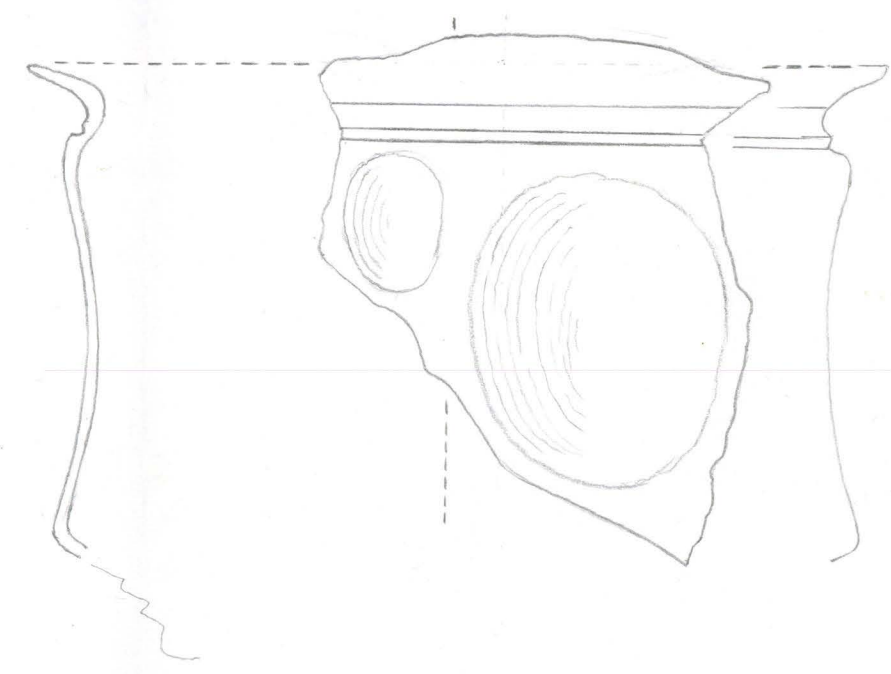
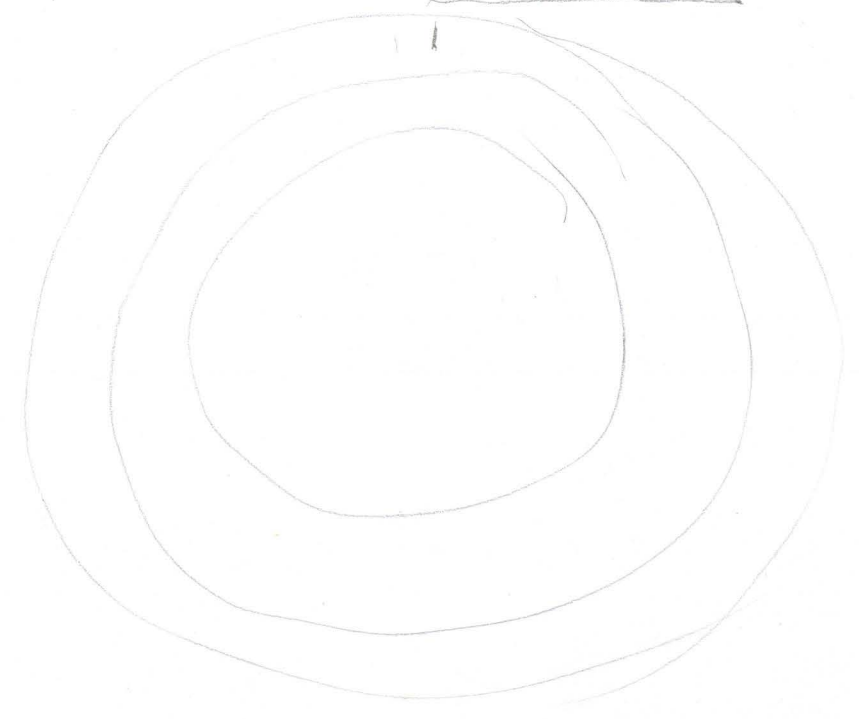
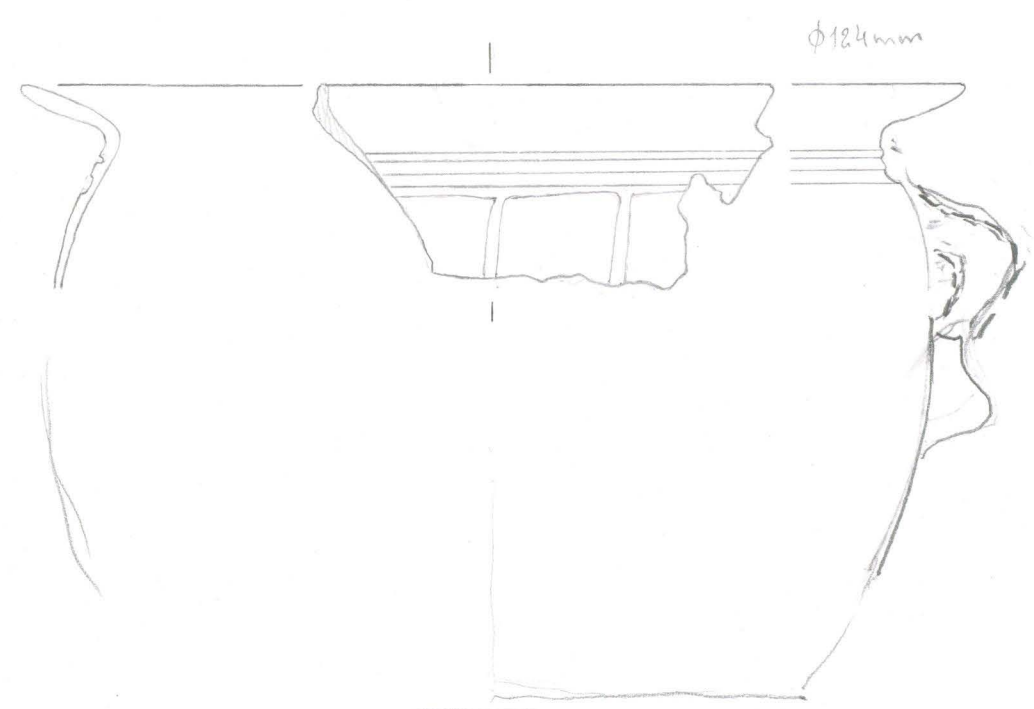

φ indeterminável
22. 3.00
Flz Sond. 41 II
Terra castanha arenosa

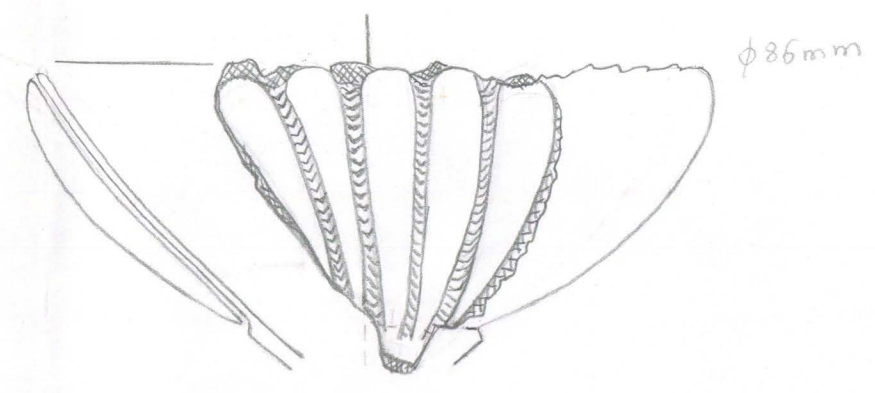

30.6.97 D'9 I

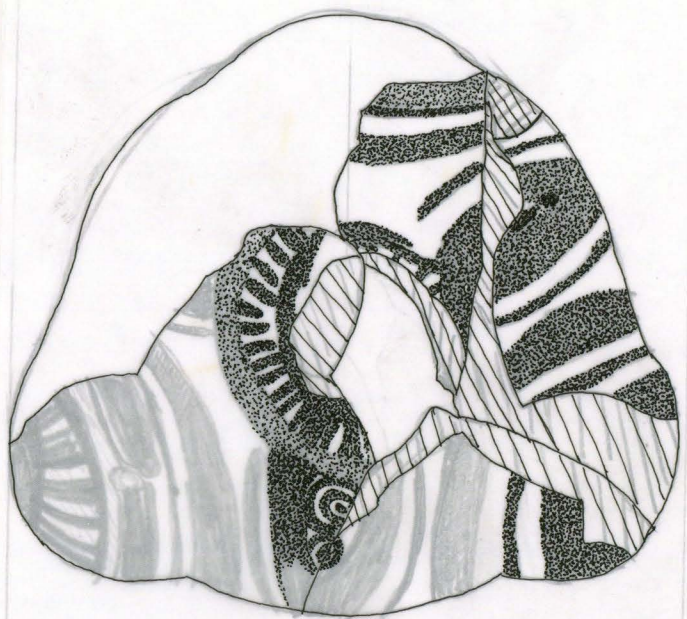
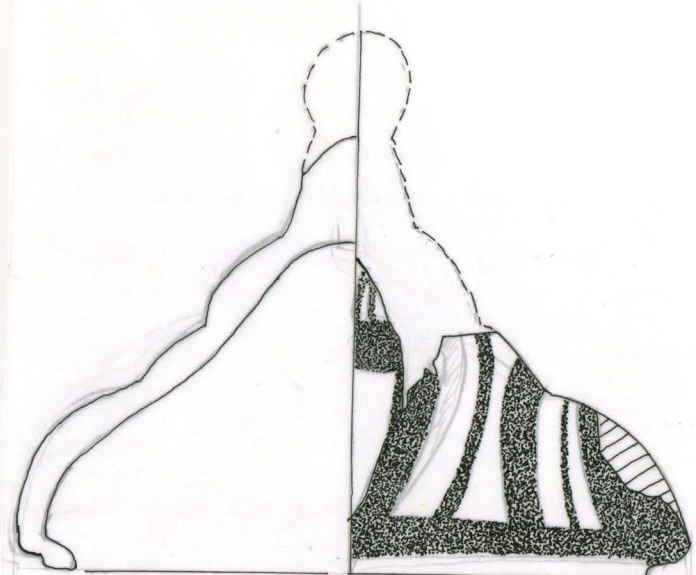

PORCELANA

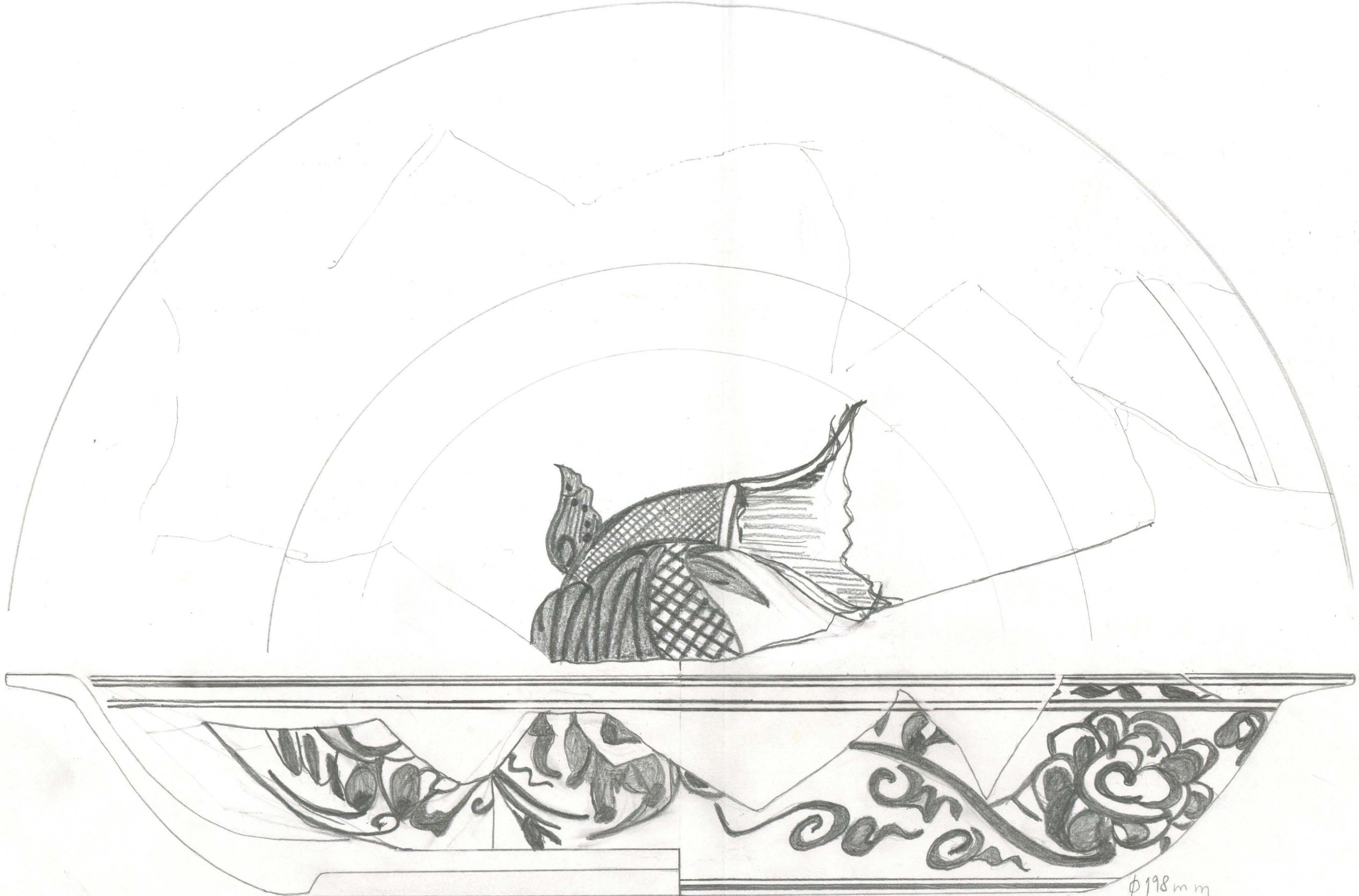

φ332mm

φ198mm

SCV 97 P.2603, 851, 2504, 1853, 4018

Hongzhi c.1500

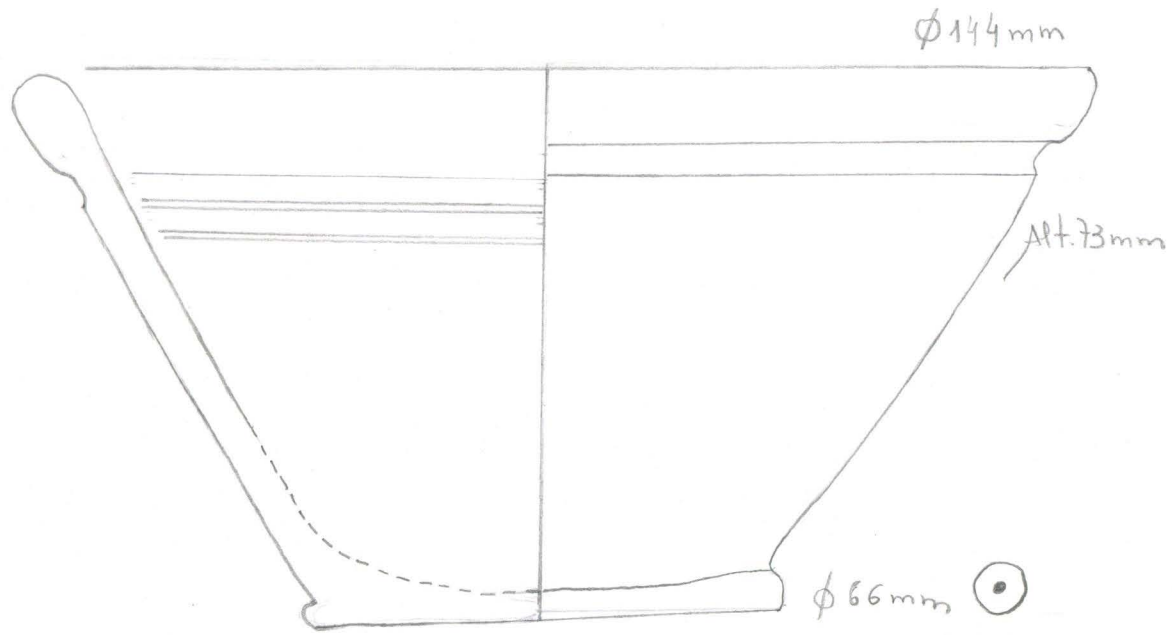

A1 Q.I Sob enterramento
30.7.96 Pasta alaranjada
Parede iconográfica em zona d'órbidos

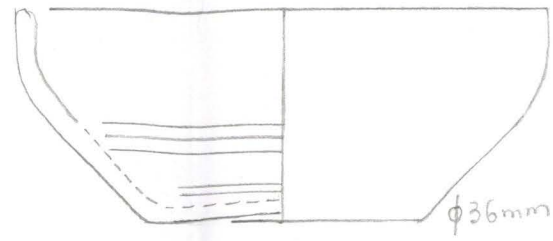

A1 Q.I
Encostado à parede
14.8.96

fig. 29b

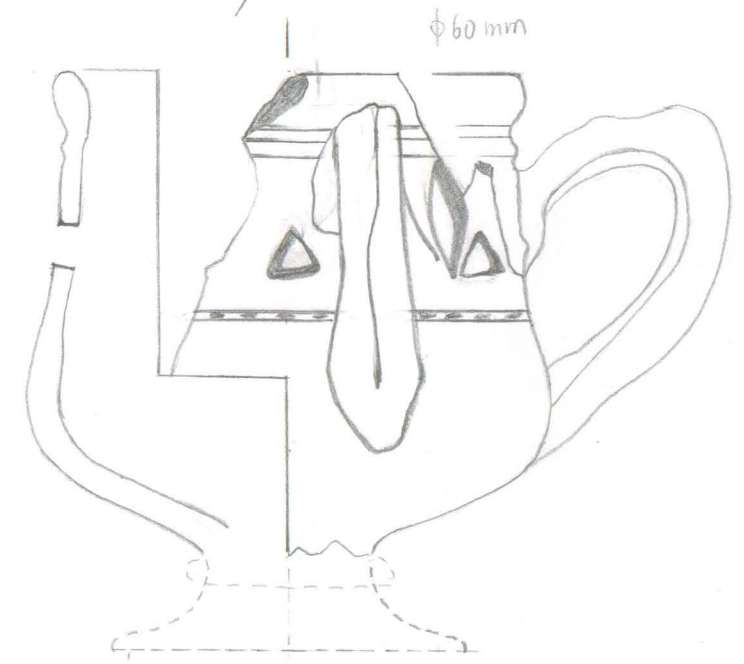

E'1 Q.III Lodo 28.1.97
Vidrado verde - Cerâmica vazada



- "grotesco"
- → grãos de quartzo
- → incisões
- ⊙ → depressões
- 〰 → modelação
- ▬ → fracturas

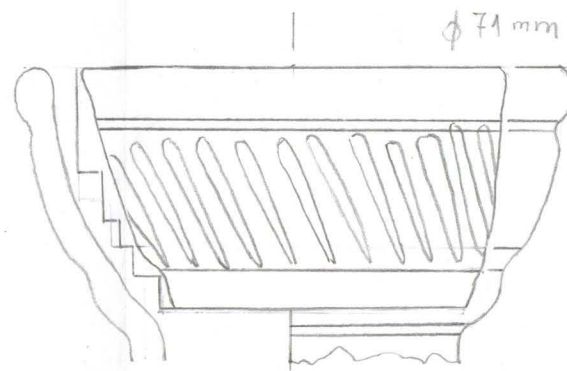

A1 Q.I 18.6.96

= infusa
análoga a uma "de negro"
Esta é vidrada a verde. A
pasta é branca e aparece
abaixo das incisões fundas
praticadas no bocal.

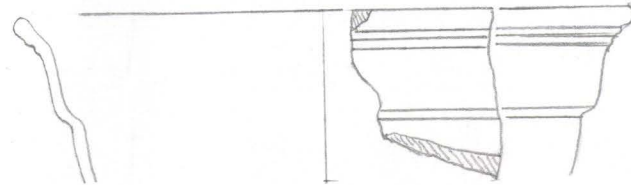

A1 Q.I 18.6.96
Vidrada a verde; pasta branca

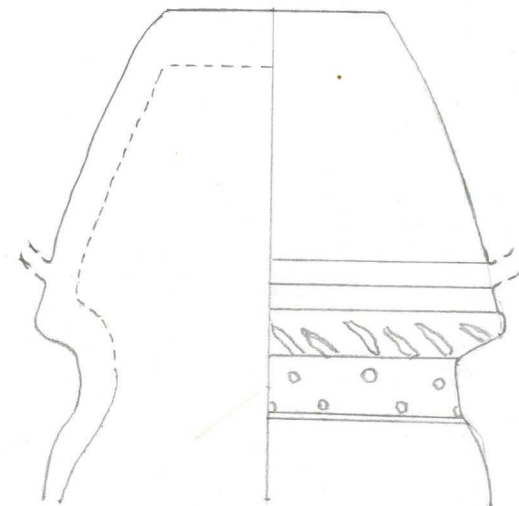

A1 Q.I
18.6.96

Comum, sem revestimento
Pasta alaranjada

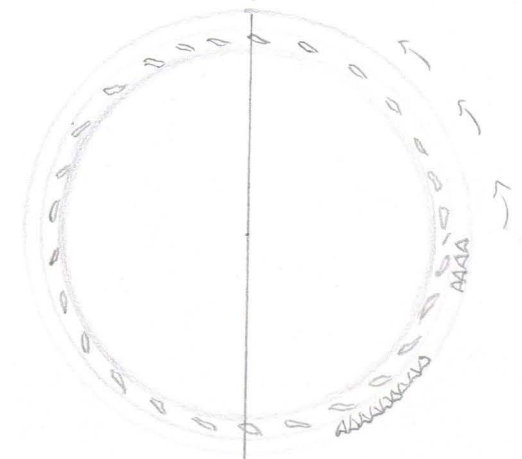

Comum vidrada

φ302mm

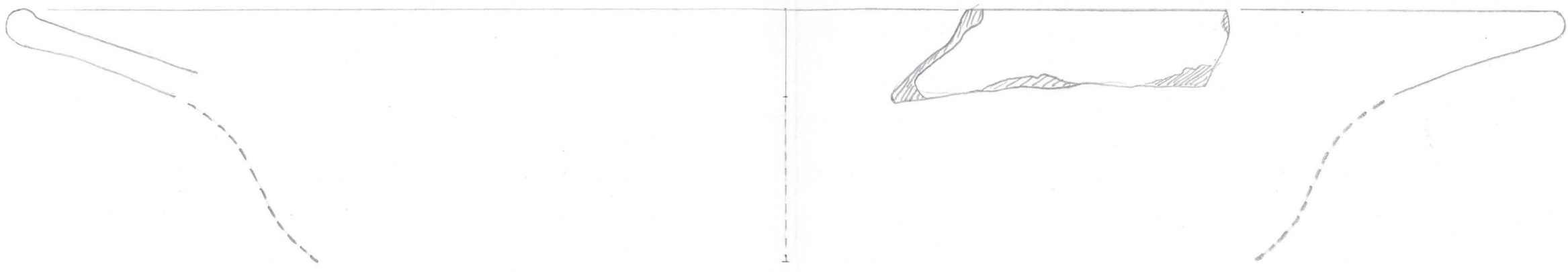

B'1 A. IV Park-

Vidrada-

CERÂMICA NEGRA
CERÂMICA VIDRADA A VERDE

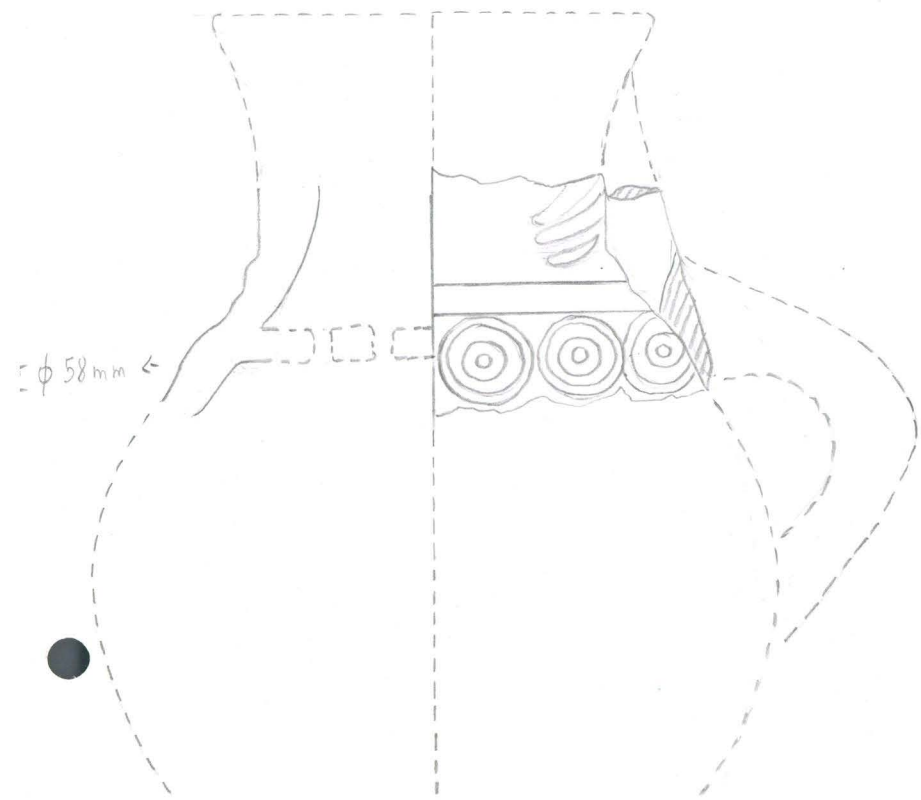

13.3.97 E'7 Q. IV
Metade Oeste da floreira
Pasta branca
Vidrado verde (meth. —)

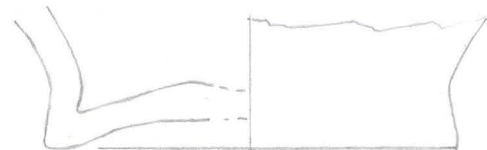

13.2.97 F'3 Q. II Lodo
Pasta branca
Vidrado verde (meth. —)

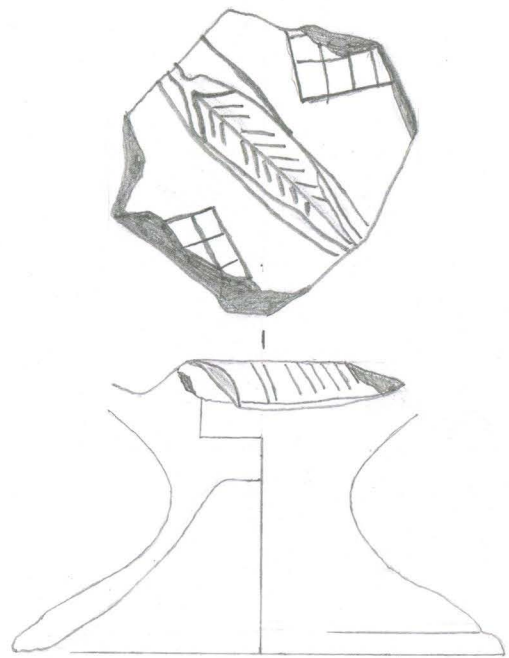

3.2.97 F1 Q. II Lodo negra
φ64 mm

- c/ engobe
- incrustada
- pintada
- c/ vidrado verde

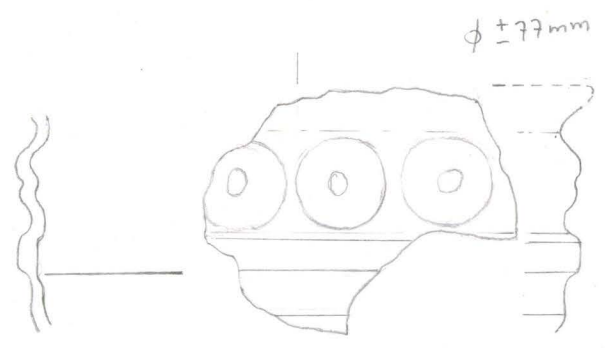

18.8.96 A1 I Sob enterramento
Tb. em D'7 (6.2.97) **FIG. 12a**

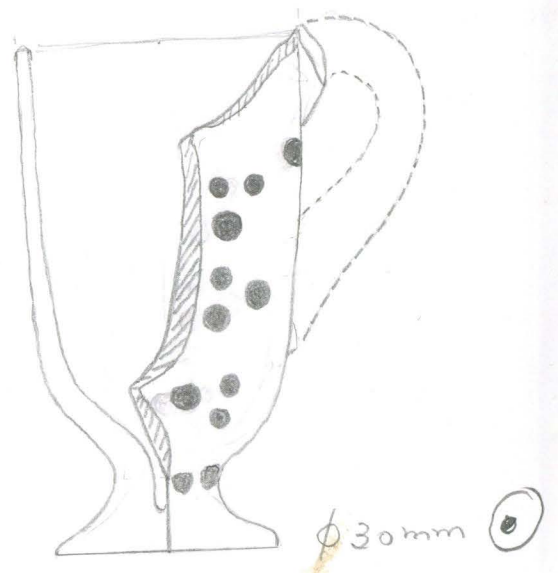

? — II Camada de Cerâmica
● - pintura a branco

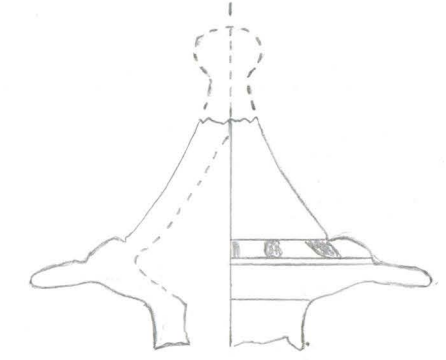
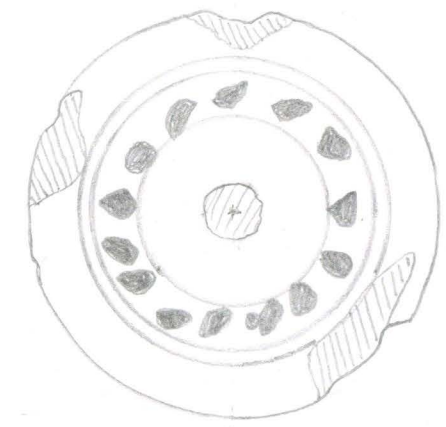

18.6.96 A1 I
Pasta Engobe
- incisões **fig. 21c**

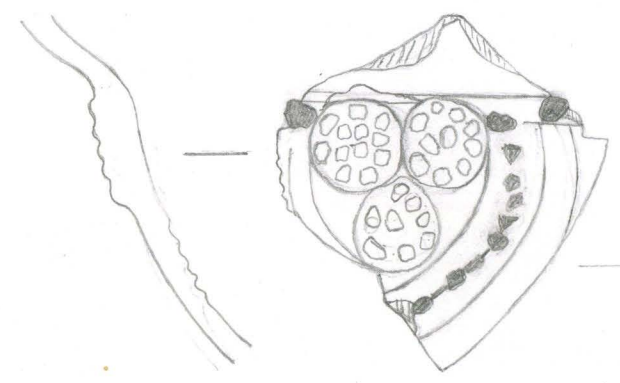

30.11.01 A1 - Ala Norte do Cão
II - Camada de cerâmica
Cota média 13.77
● - grãos de quartzo

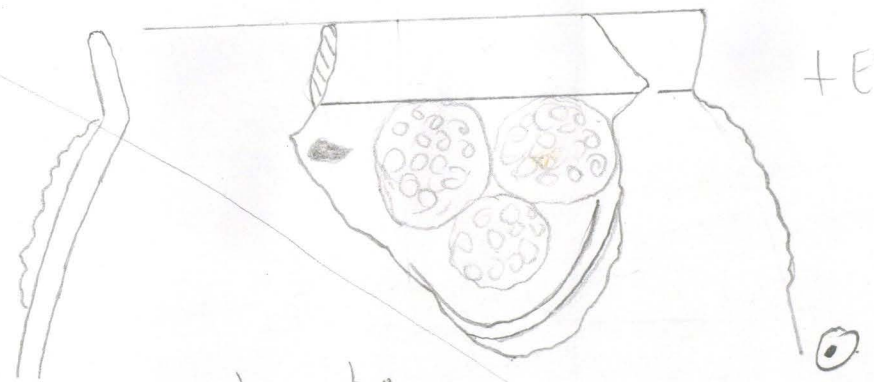

● - grão de quartzo
engobe laranja claro
FIG. 12b UMA HIERARQUIA DE TAMPAS

+ ESCAMAS

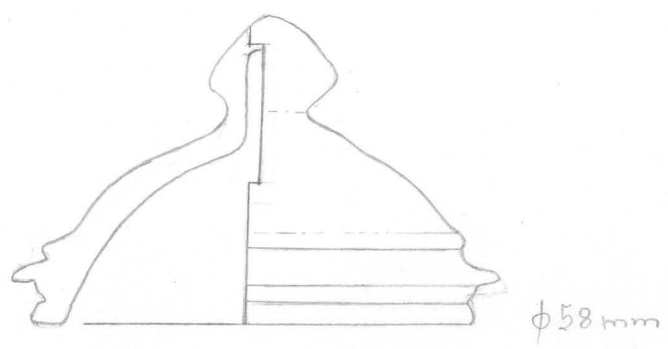

1997 E1 Q. II - IV Crivo

p. 60 n. 169 **fig. 21b**

a tampa vidrada (mourisca)

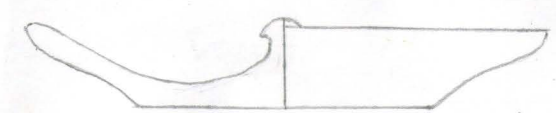

18.3.97 MAT OESTE DA FLOREIRA

o Testo (vernáculo)

a tampa vidrada rasgada (mourisca)

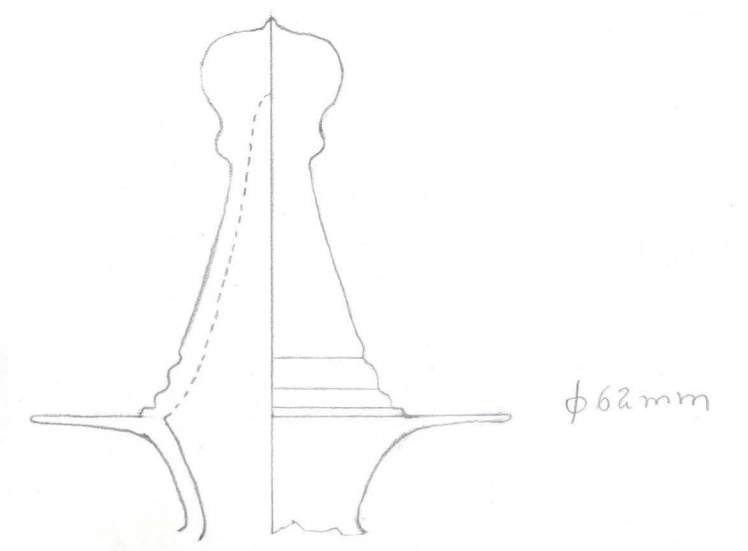

21.1.97 D'1 II Lodo
a tampa engobada (erudita, arquitectónica)

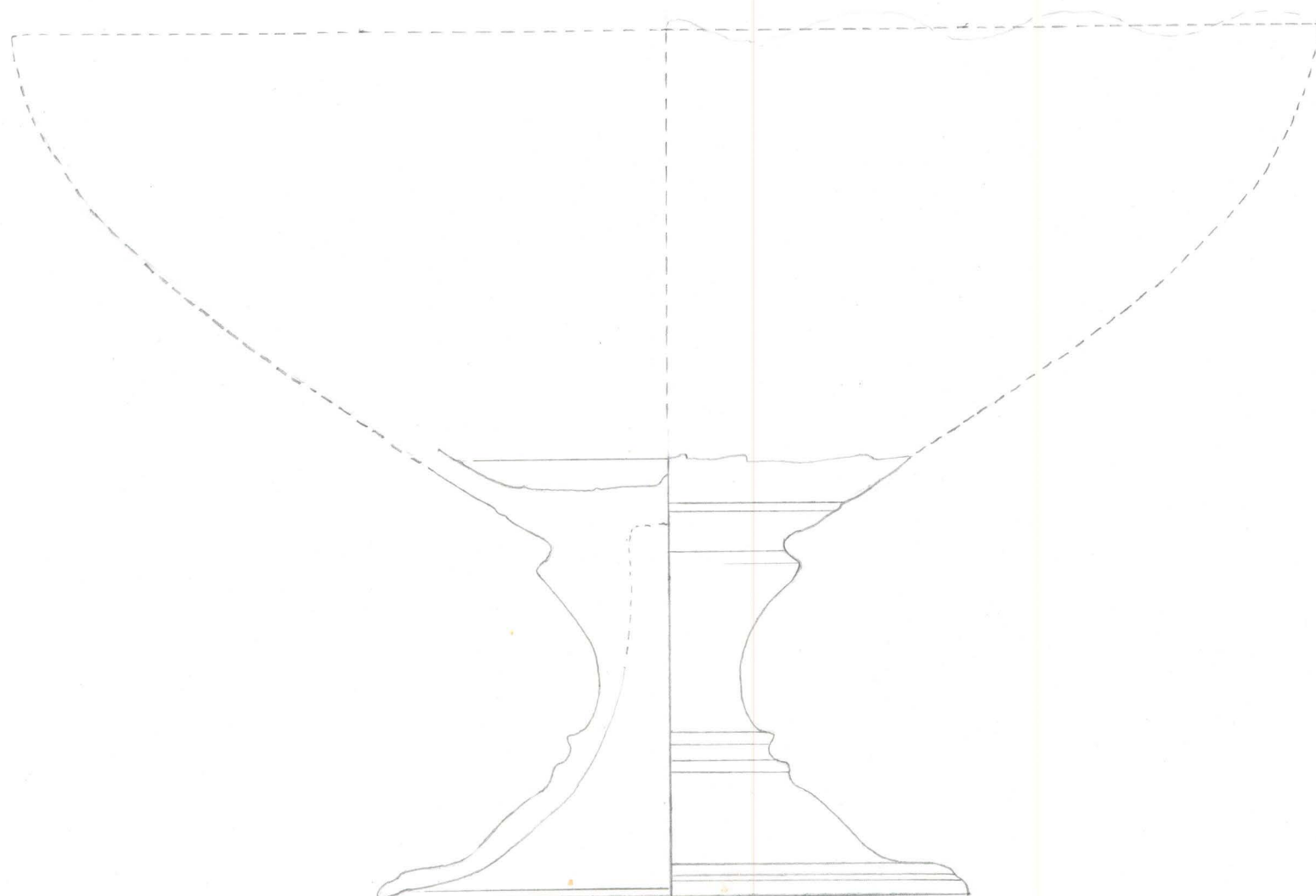

Marcado - SCV 2001 A1 Q.I N779 } ? $\phi 93 \text{ mm}$
Etiqueta { incrustado à parede }
Reconstituído

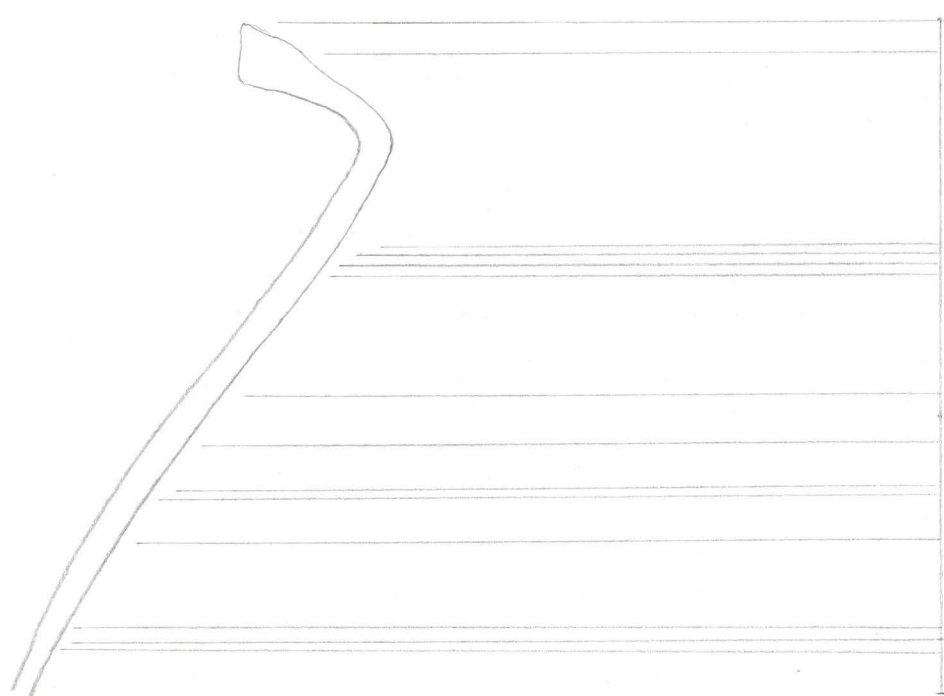

530

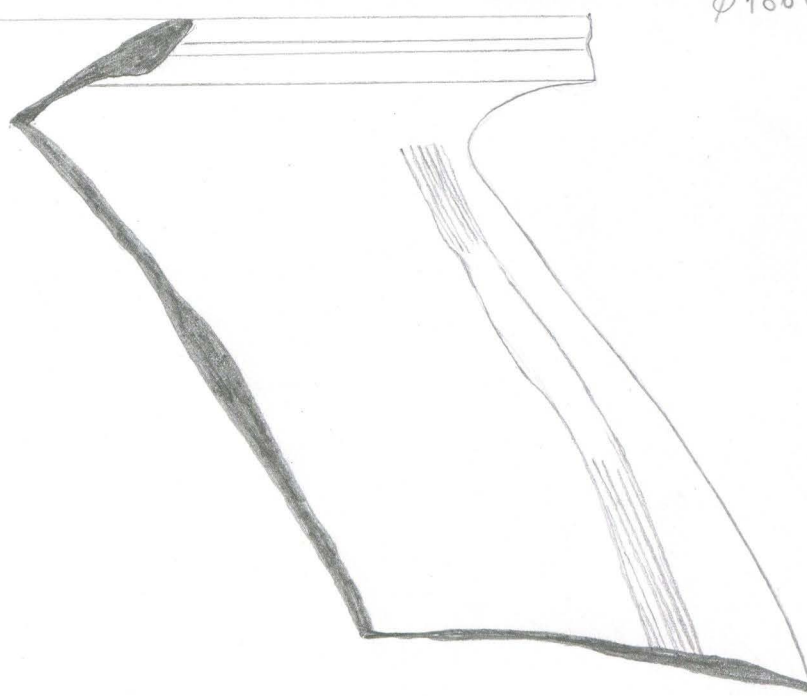

$\phi 186 \text{ mm}$

glazura negra
f

20mm

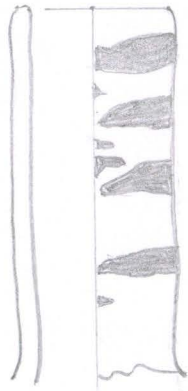

Contornos irregulares
Pasto
■ - pintura a branco

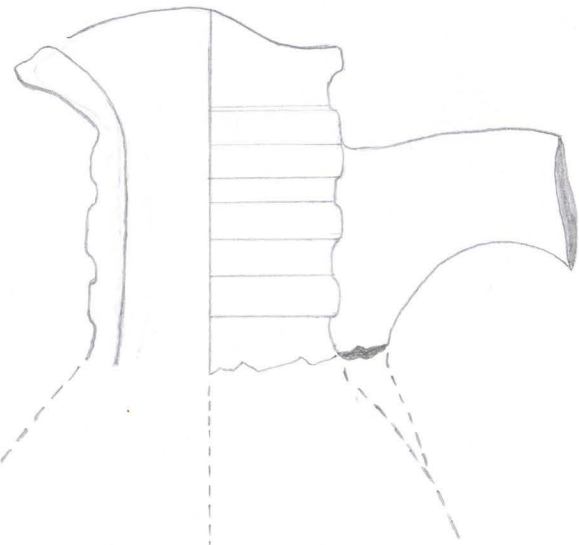
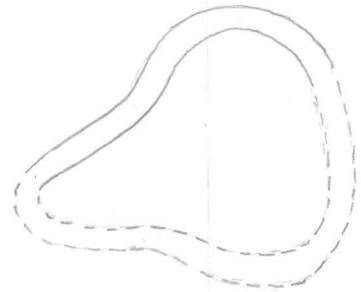

SCV 1996 A1 Q.I N. 811

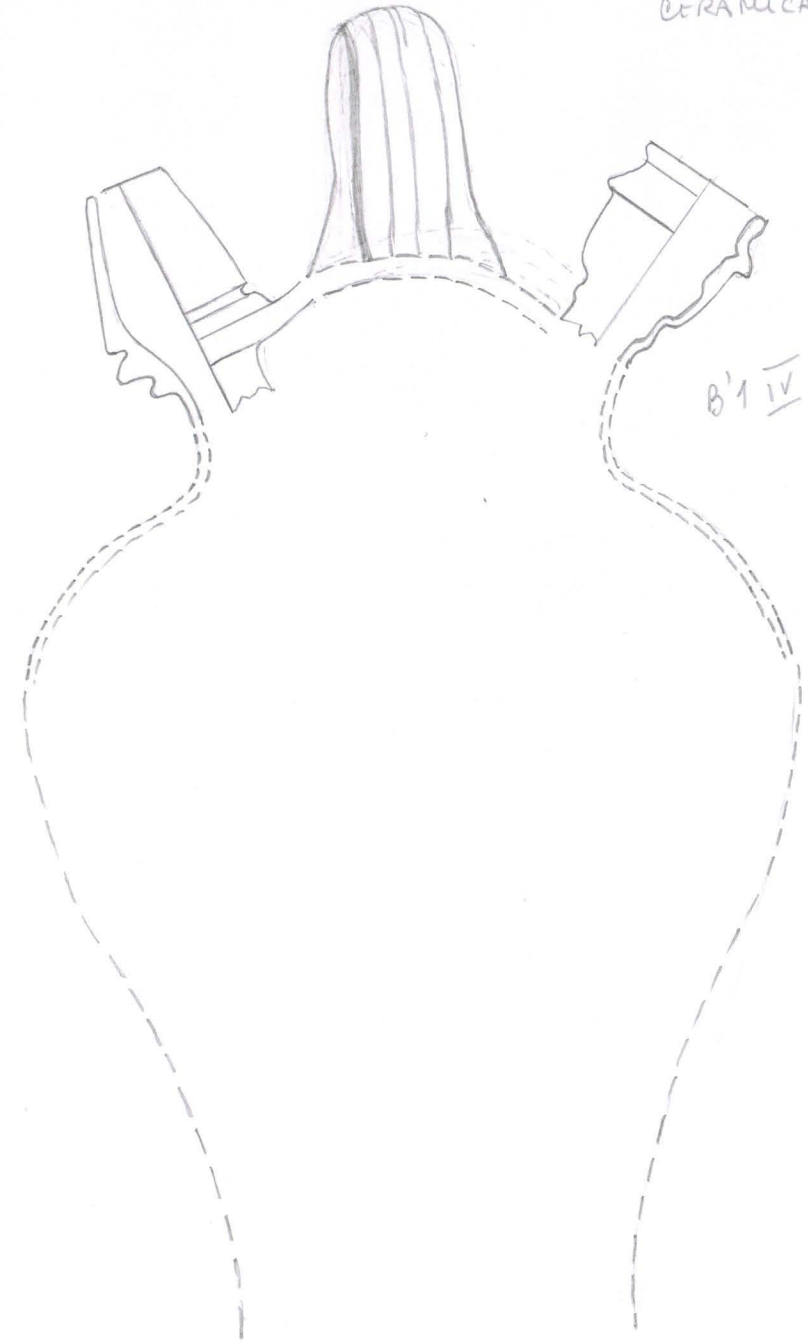

B'1 IV

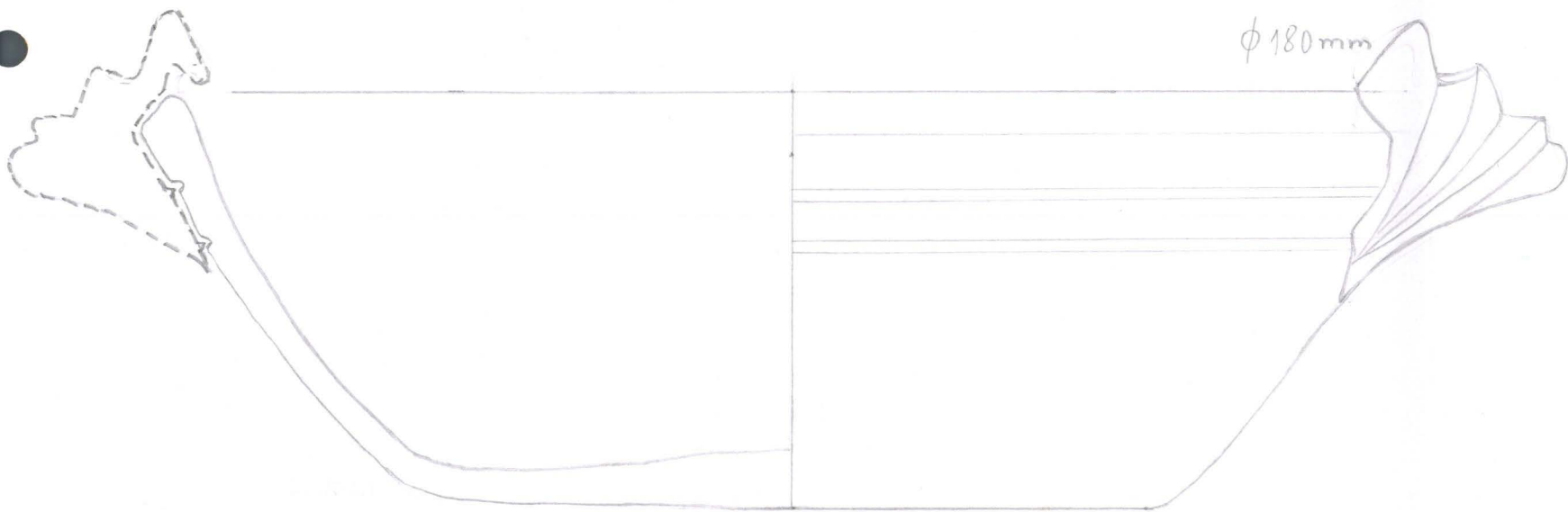

φ 180 mm

φ 104 mm
Alt. 61 mm

?
Pasto -
Vidro do interno amarelo
Vestígios de exposição ao fogo, na base
Base muito ligeiramente convexa

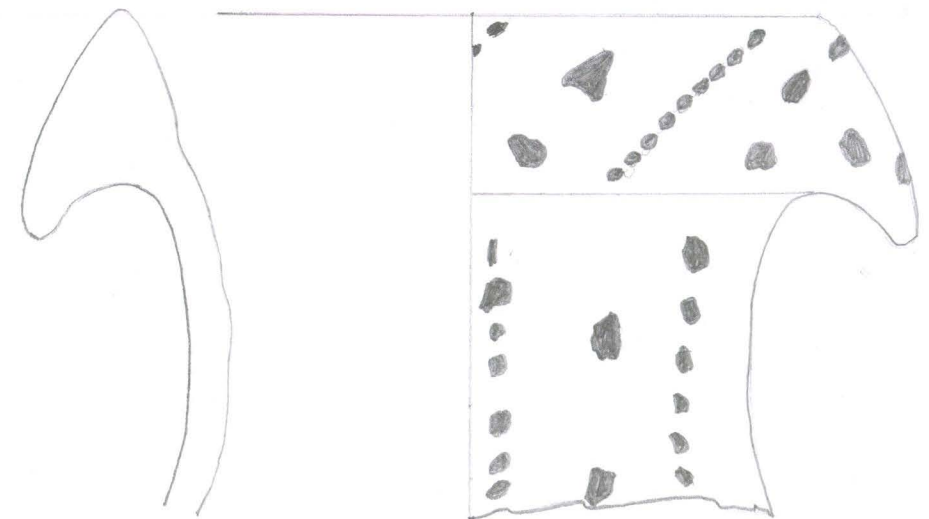

φ 92 mm

SCV 2001 A1 Q.II N. 774

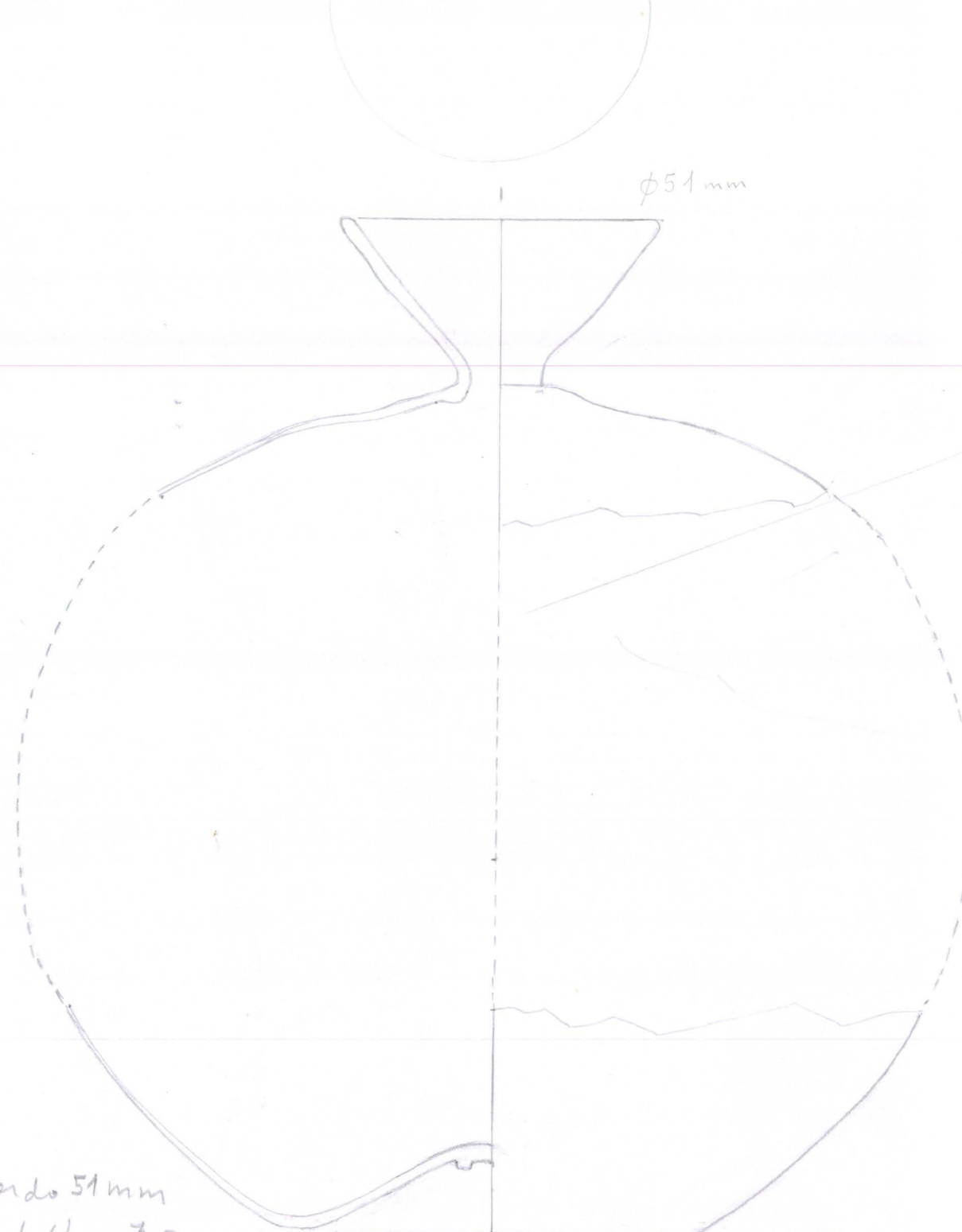

ϕ do bordo 51 mm
 ϕ do fundo/base 72 mm
 Alt. provável 168 mm

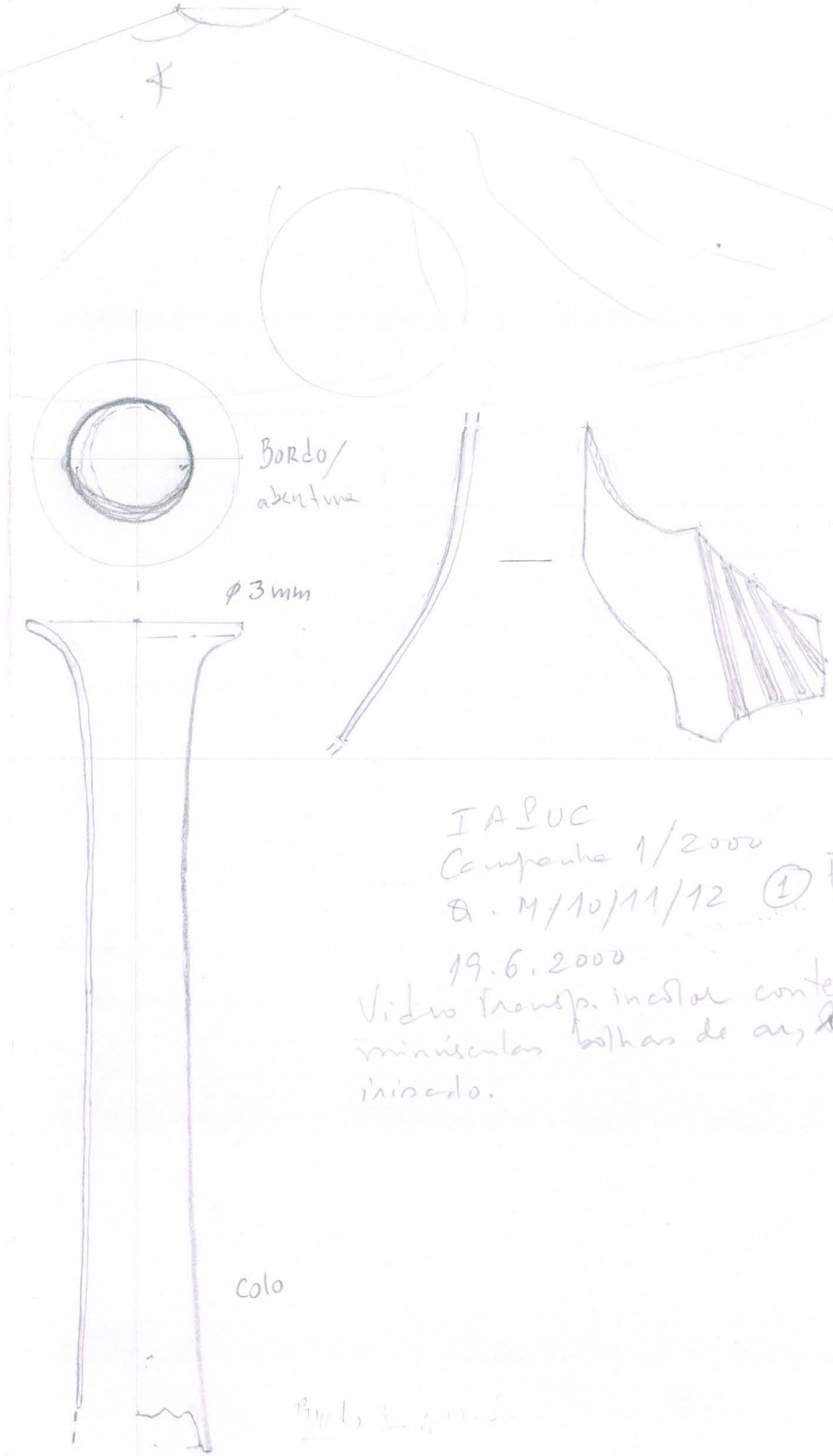
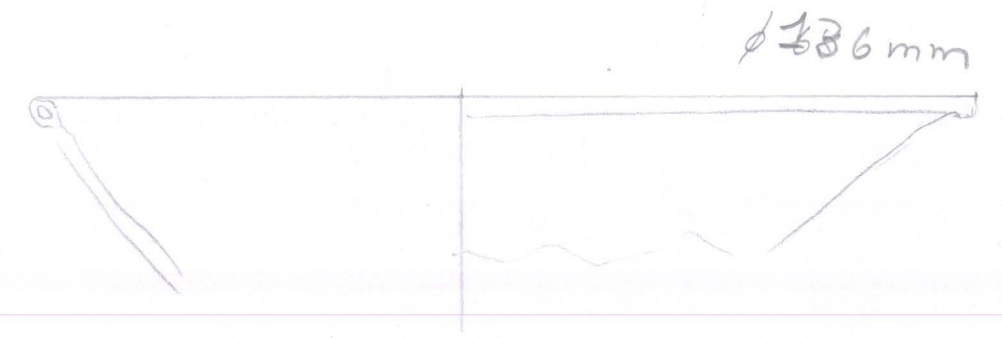

Bordo/
 abertura
 ϕ 3 mm

- branco
 opaco
 pintado in situ

IAPUC
 Campanha 1/2000
 Q. M/10/11/12 ① Entulheira
 19.6.2000

Vidro transp. incolor contendo alg.
 minúsculas bolhas de ar, ligeiramente
 irrisado.

Colo

Transp. verde acinzentado (Methuen 29 B2)
 Numerosas bolhas de ar de pequenas dimensões e formato alongado
 ligeiramente achatado. ϕ 3 mm

Cerâmica comum

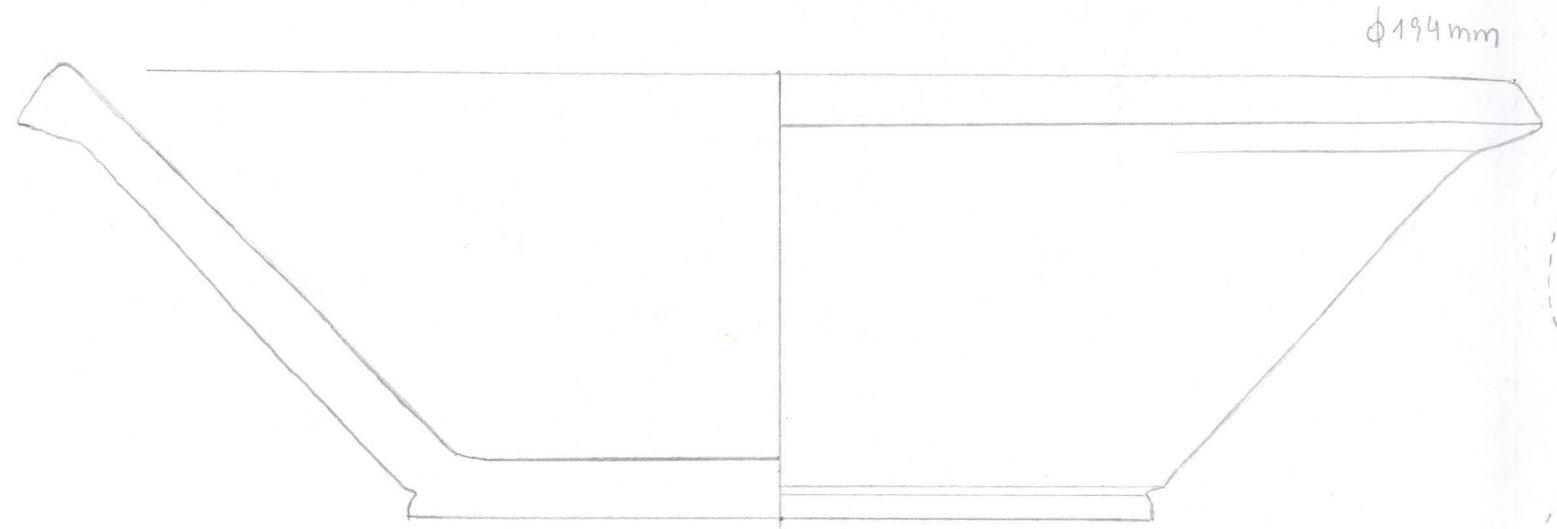

φ194mm

CC 1240 SCV 95 B11
Pasta -
Alt. 60mm φ 98mm
Vidrado -

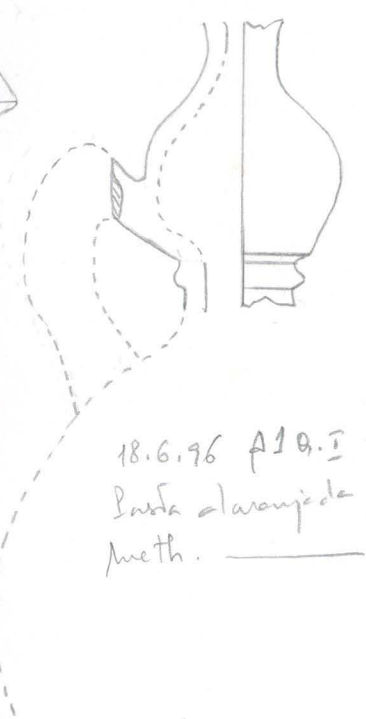

18.6.96 A1 Q. I
Pasta alaranjada
Meth. _____

φ258mm

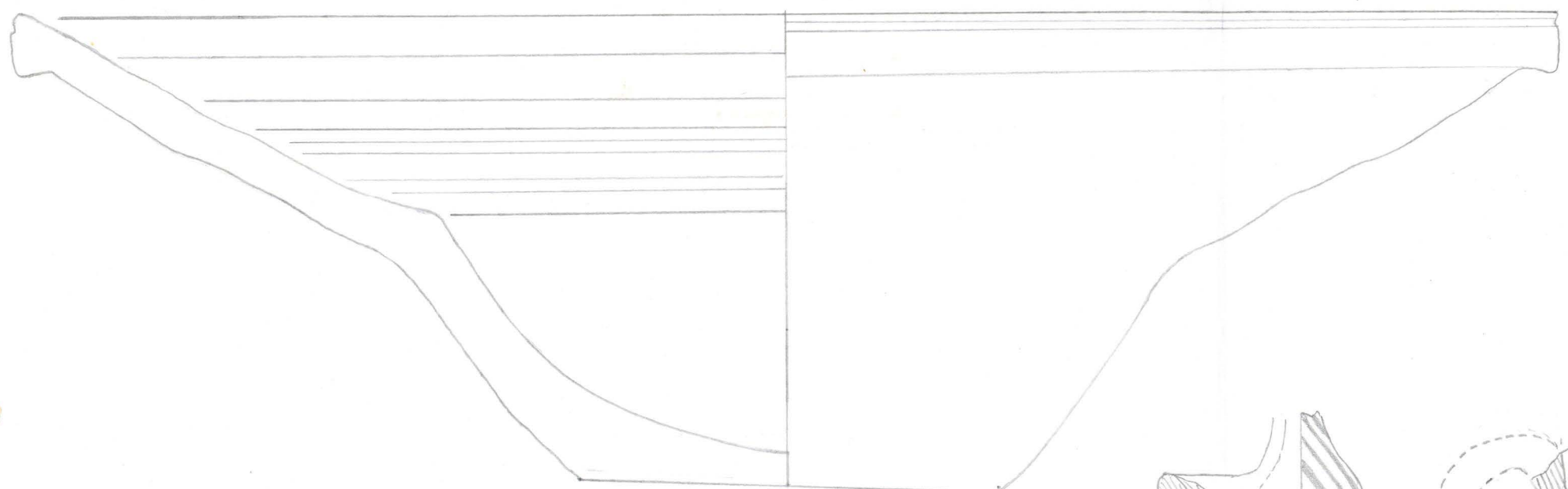

SCV 97/2/26 F'3 Q. I Lodo ec 150
Pasta -
Engobe -

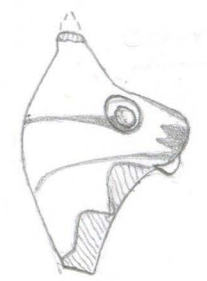

22.3.00 F'2 Sond. 41 Q. II
Camada castanho arenosa
- Pintura a branco

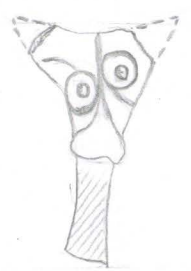

Camelinho (resgo)?

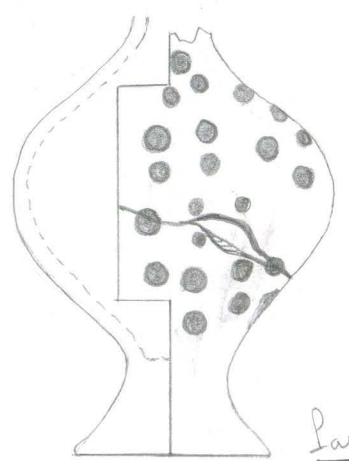

Para colar φ26mm

18.6.96 A1 I - pintura a branco.
Veiam-se os círculos brancos agrupados
a quatro, embora dispostos, estes con-
junto, de forma imperfeita.

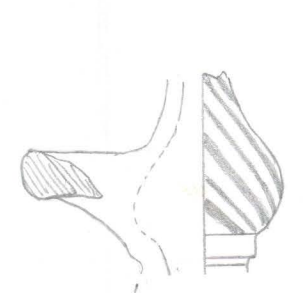

18.6.96
A1 Q. I
- pintura
a branco
pasta
(alaranjada)

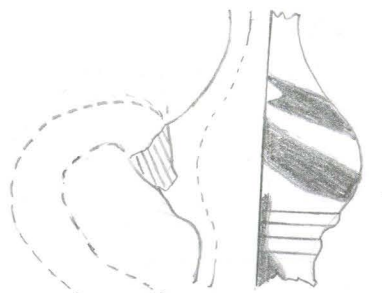

18.6.96
A1 Q. I
- pintura
a branco
pasta
(alaranjada)

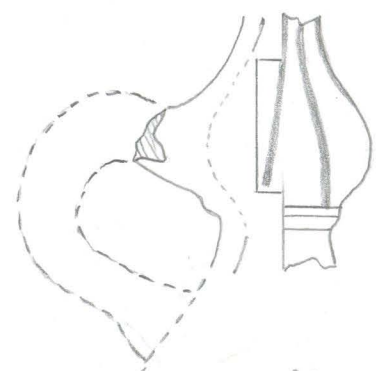

18.6.96
A1 Q. I
- pintura
a branco
pasta
(alaranjada)

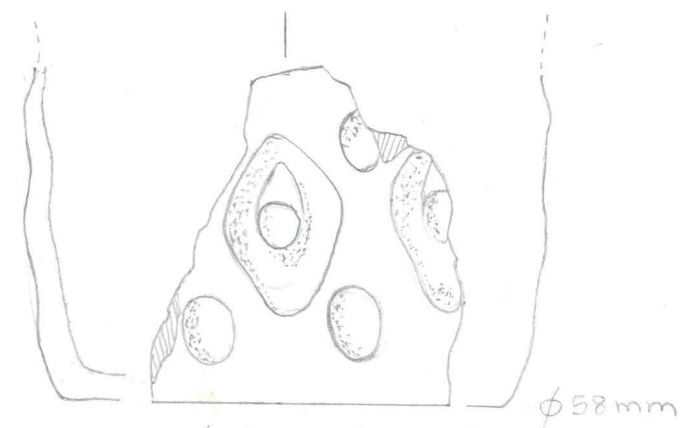

SCV 96/2/16 C'1 Q. II
Pasta castanho alaranjada (?) - Meth. _____

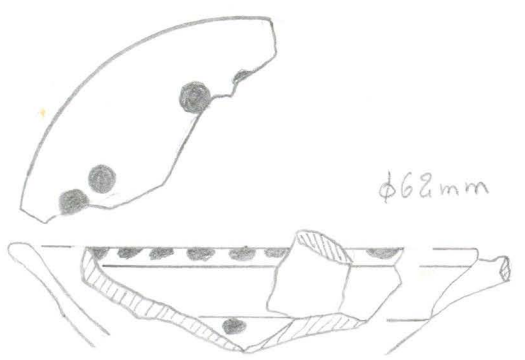

1996 A1 II - Pintura
a branco Pasta alaranjada
(Meth. _____)

φ62mm

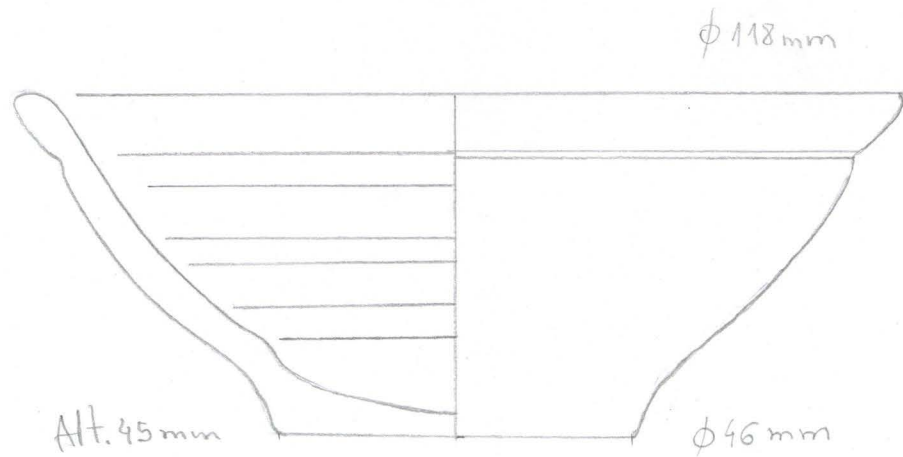

CC 1065
 SCV 97, 12, 27 F'5 Q. III
 Ext. elástico Lodo Vestígios de fogo
 Pasta -
 Engobe -
 C/ mica e alguns grãos de quartzo
 fig. 29 e

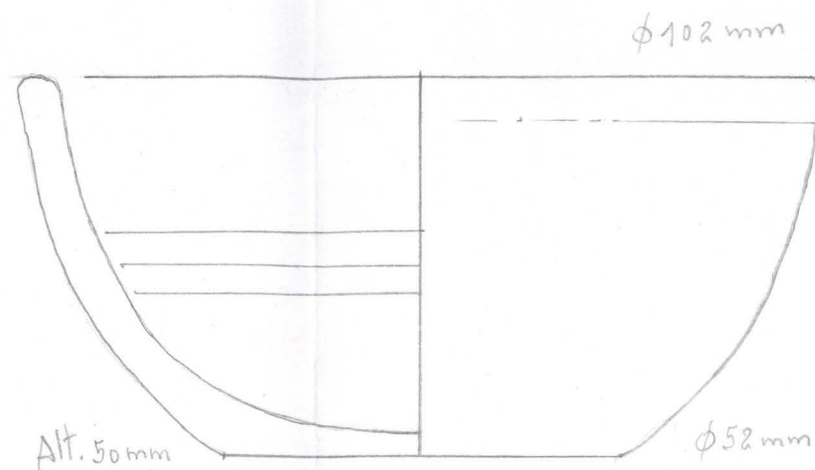

CC 1068
 SCV 2001.10.13 Quintal D. Irene
 Superficial Vestígios de fogo
 Pasta -
 Engobe -
 fig. 29 d

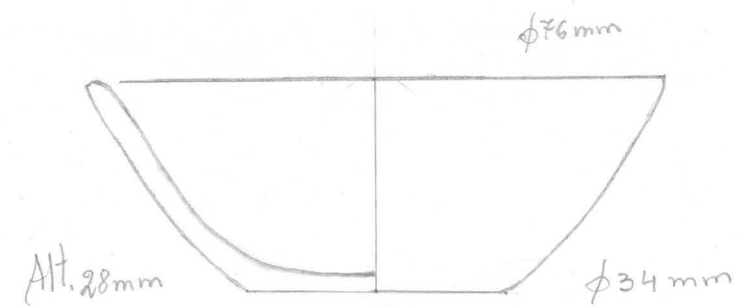

A 1 Q. I Cota abaixo 14.38
 1996.07.18 Com mica
 Pasta -
 Casca de berbigão no interior

fig. 29 c

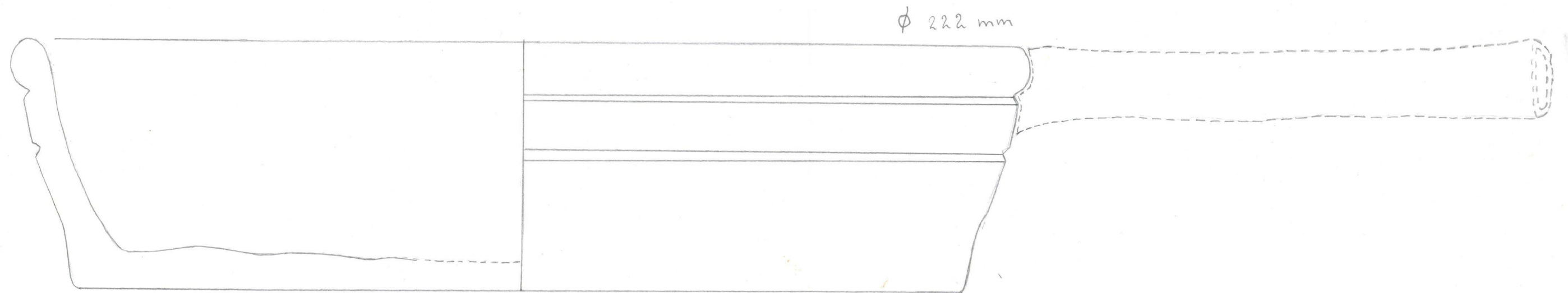

nº 1239 SCV 96 B'1 Est. 7 Pasta: Engobe:
 fig. 13b - p. 16
 Alt. 59 mm φ 206 mm

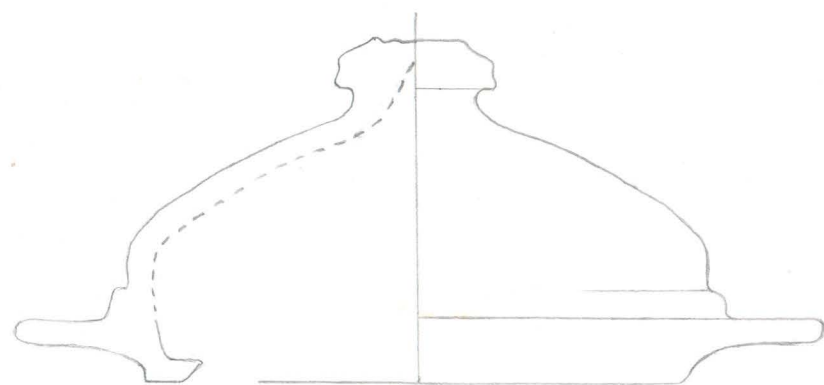

SCV 96 C9 Q. III N. 254 φ 70 mm
 CC 1088 Pasta alaranjada (meth. —)
 27.2.06

fig. 21a